



Edwards

SAPIEN M3 Transcatheter Mitral Valve Replacement System

Instructions for Use

CAUTION: Federal (USA) law restricts these devices to sale by or on the order of a physician.

Implantation of the SAPIEN M3 dock and SAPIEN M3 transcatheter heart valve should be performed only by physicians who have received Edwards Lifesciences training.

Please verify that you have the latest version of the instructions for use prior to using the device by visiting <http://eIFU.edwards.com> or by calling 1-800-822-9837.

1.0 Device Description

The SAPIEN M3 transcatheter mitral valve replacement (TMVR) system (SAPIEN M3 system) consists of the SAPIEN M3 transcatheter heart valve (model 9880TFX29M), SAPIEN M3 dock steerable catheter (model 9880DDS), SAPIEN M3 dock, Edwards Commander M delivery system (model 9880CM29), the SAPIEN M3 crimper (model 9880CR), and the SAPIEN stabilizer rail system (model 9880SRS).

• SAPIEN M3 Transcatheter Heart Valve (Figure 1)

The SAPIEN M3 transcatheter heart valve (SAPIEN M3 valve or valve) is a bioprosthesis comprised of a balloon-expandable, radiopaque, cobalt-chromium frame, three bovine pericardial tissue leaflets, polyethylene terephthalate (PET) fabric inner skirt, and full-frame outer skirt. The valve frame inflow and outflow are covered with expanded polytetrafluoroethylene (ePTFE). A green suture line indicates the valve frame inflow. All bovine pericardium is treated according to the Carpentier-Edwards ThermaFix process.

Figure 1: SAPIEN M3 Transcatheter Heart Valve model 9880TFX29M

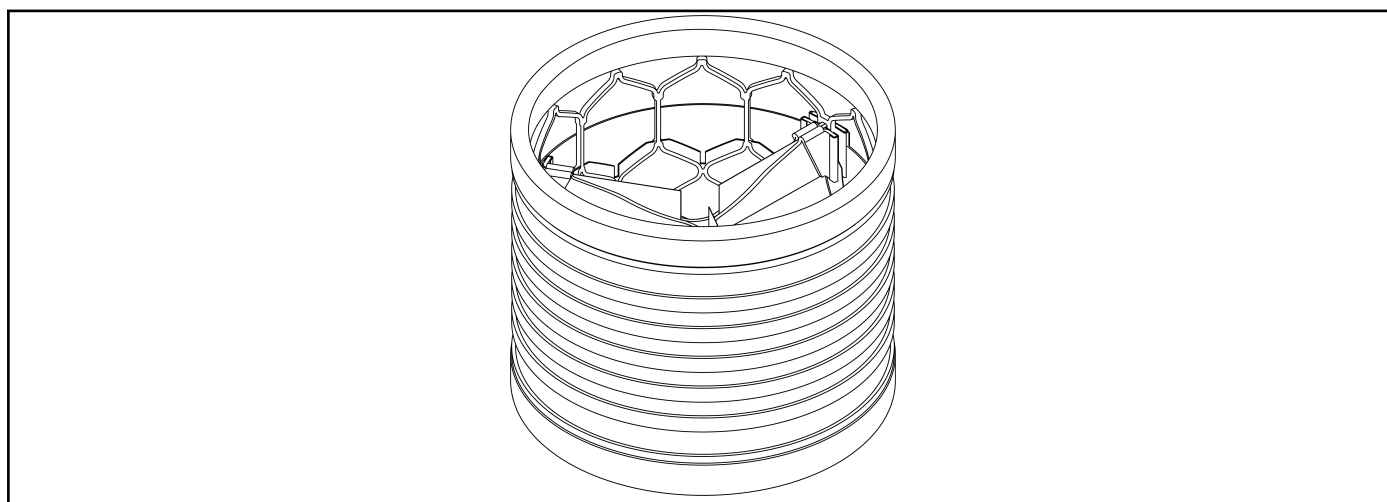

Valve Size	Valve Height
29 mm	22.5 mm

• SAPIEN M3 Dock Steerable Catheter (Figure 2)

The SAPIEN M3 dock steerable catheter (steerable catheter) is comprised of a dock, steerable catheter, dock handle, a hydrophilic coated removable sleeve, and device preparation accessories. The steerable catheter is used for delivery of the SAPIEN M3 dock (dock) to its intended location. The removable sleeve covers the dock during encircling and is designed to facilitate encircling of the mitral apparatus and is removed after the dock is positioned in the anatomy. The sleeve has a radiopaque marker that aids in visualization. The dock handle aids in advancing and/or retrieving the dock and can be locked to the steerable catheter. A release assembly at the proximal end of the dock handle allows for suture slack or suture tension. The suture can be cut to release the dock from the dock handle.

The SAPIEN M3 dock is comprised of a nitinol core that is covered with ePTFE tubing and PET braid, with a self-expanding PVL guard made of a PET covered nitinol braid. The dock encircles the native mitral leaflets which applies an inward force to the mitral apparatus, pulling the leaflets and chordae to the dock center and approximating the papillary muscles, to provide a landing zone for the SAPIEN M3 valve. The dock includes one (1) radiopaque marker to visualize proper deployment positioning within the anatomy, and two (2) radiopaque markers to visualize final deployment positioning of the PVL guard. The PVL guard expands at the medial commissure of the native mitral valve.

Figure 2: SAPIEN M3 Dock Steerable Catheter model 9880DDS

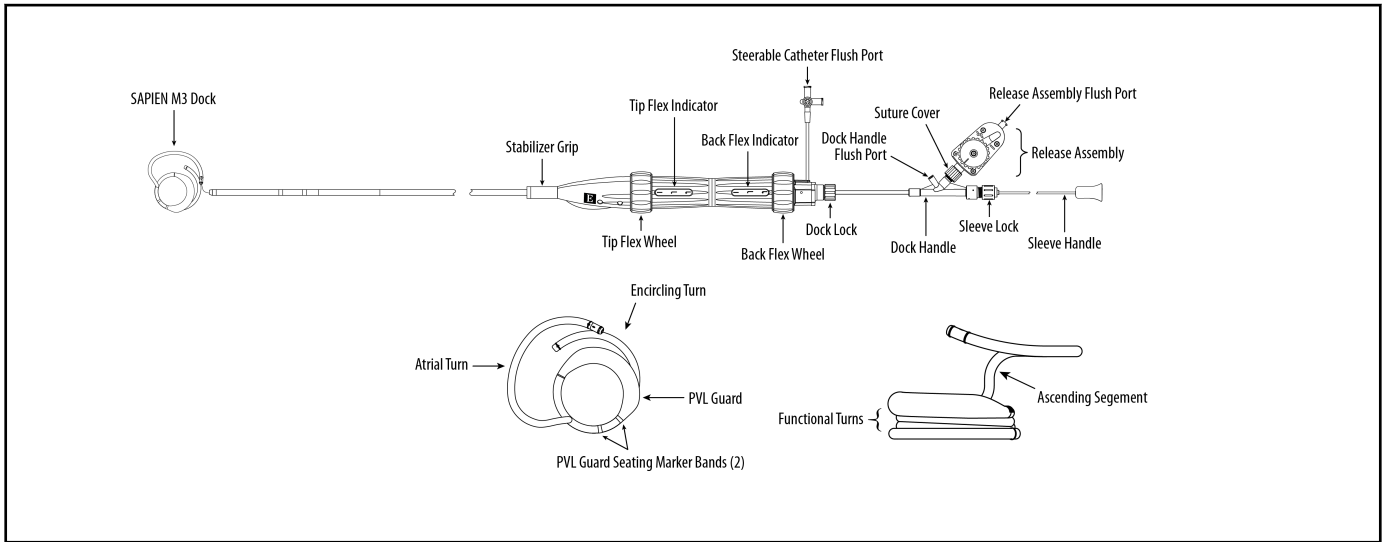

Model	Shaft Effective Length	Shaft O.D.
9880DDS	113 cm	18 F (6.2 mm)

• Edwards Commander M Delivery System (Figure 3)

The Edwards Commander M delivery system (valve delivery system) is comprised of a balloon catheter and a flex catheter with a tapered tip. The Edwards Commander M delivery system is used for delivery of the SAPIEN M3 valve. The handle contains a flex wheel and a balloon lock and the balloon catheter has radiopaque markers. The radiopaque markers indicate the flex catheter and guide sheath position during deployment and define the crimp location for the valve.

The inflation parameters for valve deployment are:

Model	Shaft Effective Length	Shaft O.D.	Inflation Volume	Balloon Outer Diameter
9880CM29	112 cm	16 F (5.4 mm)	33 ml (initial)	30 mm
			37 ml (post-dilation)	31 mm

Figure 3: Edwards Commander M Delivery System model 9880CM29

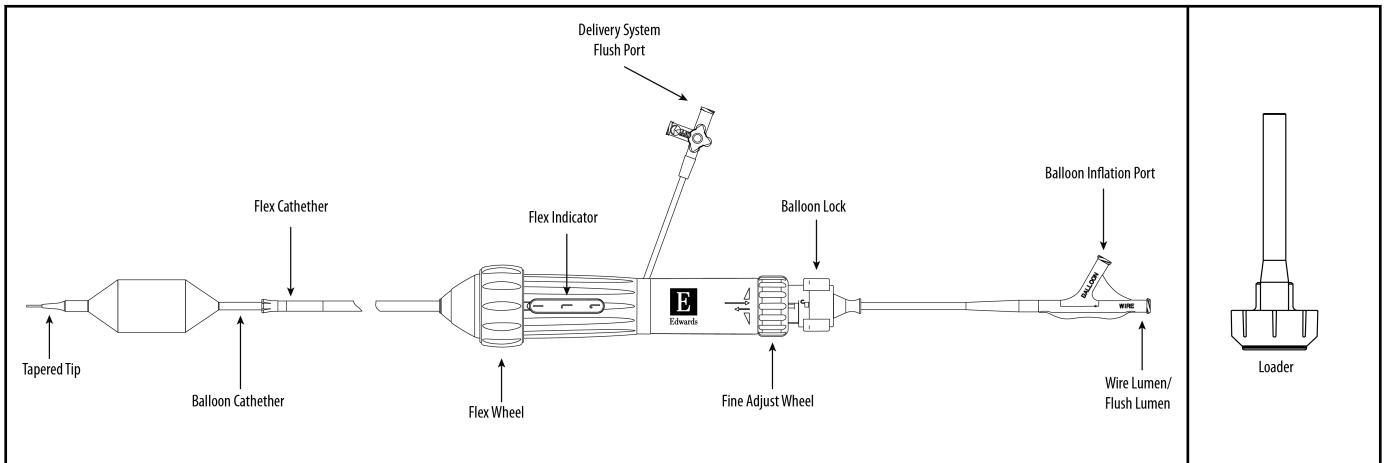

• SAPIEN Stabilizer Rail System (Figure 4)

The SAPIEN stabilizer rail system (SRS) includes a rail and two (2) stabilizers, and holds the guide sheath and the steerable catheter to support and maintain catheter positioning. The SRS must be used in conjunction with the supporting Edwards reusable accessories.

Figure 4: SAPIEN Stabilizer Rail System model 9880SRS

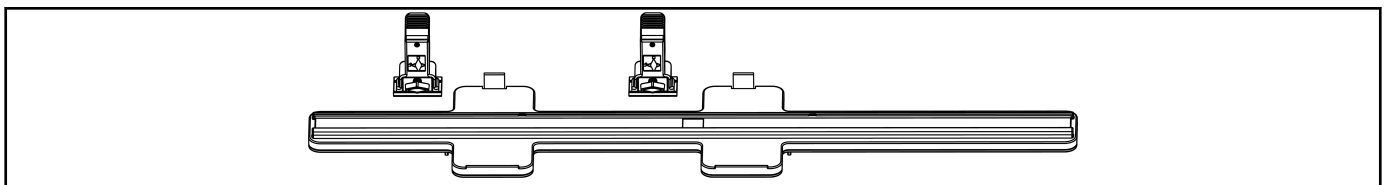

• **SAPIEN M3 Crimper (Figure 5)**

The SAPIEN M3 crimper (crimper) is comprised of a housing and compression mechanism. The crimper reduces the diameter of the SAPIEN M3 valve while compressing it onto the delivery system. The crimp stopper is used to crimp the valve to its intended diameter.

Figure 5: SAPIEN M3 Crimper model 9880CR

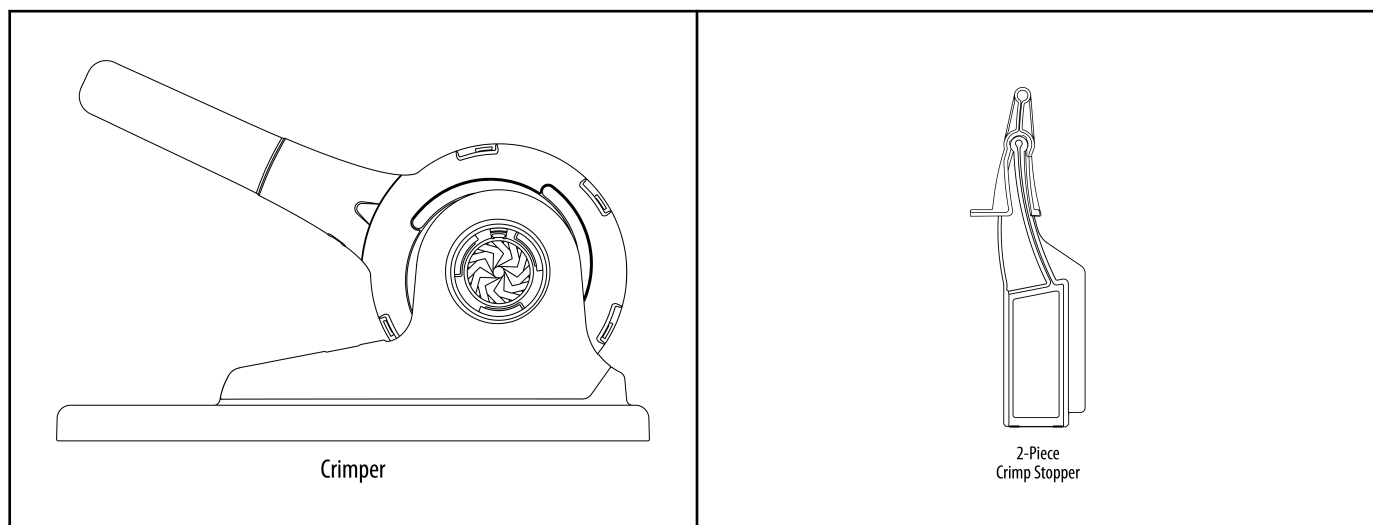

The SAPIEN M3 system is intended to be used with:

Product Name	Model/REF
Edwards 23F Guide Sheath ^[1]	9880GS
Edwards Locking Syringe	96406
^[1] Includes an introducer	

• **Edwards 23F Guide Sheath**

For Edwards 23F guide sheath (guide sheath), refer to Edwards 23F Guide Sheath Instructions for Use (herein referred to as Edwards 23F Guide Sheath IFU).

• **Edwards Locking Syringe**

For Edwards locking syringe (inflation device), refer to Edwards Locking Syringe Instructions for Use (herein referred to as Edwards Locking Syringe IFU).

Note: For proper volume sizing, the Edwards Commander M delivery system should be used with the inflation device provided by Edwards Lifesciences.

The SAPIEN M3 system is intended to be used with the following supporting devices:

Edwards reusable accessories:

Product Name	Model/REF
Edwards Reusable Platform	10000UP
Edwards Reusable Plate	10000PT
Edwards Reusable Cradle	10000CR

• **Edwards Reusable Accessories**

For Edwards reusable accessories (reusable accessories), refer to Reusable Platform (Model 10000UP), Reusable Plate (Model 10000PT), and Reusable Cradle (Model 10000CR) Instructions for Use (herein referred to as Edwards Reusable Accessories IFU).

2.0 Indication for Use

- The SAPIEN M3 transcatheter mitral valve replacement system (SAPIEN M3 system) is indicated for the treatment of symptomatic moderate-to-severe or severe mitral regurgitation (MR) in patients who are deemed unsuitable for surgery or transcatheter edge-to-edge repair (TEER) therapy by a multidisciplinary heart team.
- The SAPIEN M3 system is also indicated for the treatment of symptomatic mitral valve dysfunction (moderate-to-severe or severe MR, severe mitral stenosis (MS), or moderate MR with moderate MS) associated with mitral annular calcification (MAC) in patients who are deemed unsuitable for surgery or TEER therapy by a multidisciplinary heart team.

3.0 Contraindications

The SAPIEN M3 system is contraindicated in patients who cannot tolerate any anticoagulation/antiplatelet regime or intraprocedural heparin; or who have active bacterial endocarditis or other active infections.

4.0 Warnings

Failure to abide by warnings and precautions in this labeling could lead to damage of the device or device coating and may result in adverse events leading to additional intervention.

- The SAPIEN M3 system devices are designed, intended, and distributed STERILE for single use only. Do not resterilize or reuse the devices. There are no data to support the sterility, non-pyrogenicity, and functionality of the devices after reprocessing. The reusable accessories are non-sterile.
- Do not mishandle the SAPIEN M3 system devices or use them if the packaging or any components are not sterile, have been opened or are damaged (e.g., kinked or stretched), or the expiration date has elapsed.

- Patients with hypersensitivities to cobalt, nitinol (nickel or titanium), chromium, molybdenum, manganese, silicon, bovine tissue, and/or polymeric materials may have an allergic reaction/immunological response to these materials.
- Accelerated deterioration of the valve may occur in patients with altered calcium metabolism.
- Exercise caution when implanting a valve in patients with clinically significant coronary artery disease as it may result in myocardial ischemia.
- Prior to delivery, the valve must always remain hydrated and cannot be exposed to solutions other than its shipping storage solution and sterile physiologic rinsing solution. Valve leaflets mishandled or damaged during any part of the procedure will require replacement of the valve.
- Do not use the valve if the tamper-evident seal is broken, the storage solution does not completely cover the valve, the temperature indicator has been activated, the valve is damaged, or the expiration date has elapsed.
- Do not add or apply antibiotics to the storage solution, rinse solutions, or the valve.
- The physician must verify correct orientation of the valve prior to its implantation.
- The procedure should be conducted under 3D echocardiography and fluoroscopic guidance. Some fluoroscopically guided procedures are associated with a risk of radiation injury to the skin. These injuries may be painful, disfiguring, and long-lasting.
- Use of excessive contrast media may lead to renal failure. Measure the patient's creatinine level prior to the procedure. Contrast media usage should be monitored.
- Observation of the pacing lead throughout the procedure is essential to avoid the potential risk of pacing lead perforation.
- In the event of device malfunction or device damage during use (e.g., destructive deformation to the catheter, balloon burst, etc.) safely remove the device(s). If unable to safely remove the device(s), conversion to surgery is recommended.
- Prior to valve deployment, 3D echocardiographic and fluoroscopic (short-axis view) verification must be used to confirm that the guidewire passes through the center of the implanted dock and has unrestricted movement. Failure to do so can result in chordal rupture and/or the valve being deployed outside of target location.
- Incorrect positioning of the dock and/or valve may lead to left ventricular outflow tract obstruction, paravalvular leak (PVL), valve migration, or valve embolization.
- Valve recipients must be on appropriate anticoagulation regimen, determined at the physician's discretion based on individual subject needs for a minimum of 6 months. Failure to anticoagulate and bridge appropriately will lead to valve thrombosis. For subjects receiving vitamin K antagonists, target range for INR is 2.5 to 3.5. After 6 months, continued antithrombotic therapy is recommended as tolerated.

5.0 Precautions

- Glutaraldehyde may cause irritation of the skin, eyes, nose, and throat. Avoid prolonged or repeated exposure to, or breathing of, the solution. Use only with adequate ventilation. If skin contact occurs, immediately flush the affected area with water; in the event of contact with eyes, seek immediate medical attention. For more information about glutaraldehyde exposure, refer to the Material Safety Data Sheet available from Edwards Lifesciences.
- Additional precautions for transseptal replacement of a mitral valve include abnormalities in the caval vein precluding safe transvenous femoral access for transseptal approach, presence of atrial septal occluder device, or calcium preventing safe transseptal access.
- Patients with a pre-existing prosthesis should be evaluated for the location, shape, construction, and characteristics of the prosthesis (e.g., low-deployed aortic prosthesis, rigid or small annuloplasty ring, septal occluder, etc.) as it may interfere with SAPIEN M3 system deployment, functionality, or dock/valve durability.
- Patients with mitral annular calcification should be evaluated for the characteristics of the calcium and mitral pathology as it may interfere with the dock trajectory during deployment, result in malposition of the dock/valve, and/or have an increased risk of PVL.
- Patient's sub-valvular anatomy should be evaluated for the characteristics of papillary muscles, chordae, and ventricular wall as it may interfere with or prevent dock deployment.
- Patients with the following characteristics have an increased risk of PVL which may lead to hemolysis and/or intervention:
 - Compromised leaflet integrity (e.g., perforation, endocarditis, Barlow's syndrome, etc.)
 - Flail or prolapse located at the commissures
 - Flail or prolapse located at P3 leaflet in conjunction with a commissural distance ≥ 42 mm
 - Any large non-commissural flail or prolapse
- To maintain proper valve leaflet coaptation, do not overinflate the deployment balloon.
- Appropriate antibiotic prophylaxis is recommended post-procedure in patients at risk for prosthetic valve infection and endocarditis.
- Long-term durability has not been established for the valve. Regular medical follow-up is advised to evaluate valve performance.
- The safety and effectiveness of the SAPIEN M3 system have not been established for patients who have/are:
 - A left ventricular end-diastolic diameter ≥ 75 mm
 - A commissural distance ≥ 50 mm
 - A left ventricular ejection fraction below 25%
 - Severe RV dysfunction
 - History of heart transplant
 - Severe pulmonary hypertension
 - Blood dyscrasias defined as: leukopenia (WBC < 3000 cells/ μ L), acute anemia (Hb < 9 g/dL), thrombocytopenia (platelet count $< 50,000$ cells/ μ L), or history of bleeding diathesis or coagulopathy

6.0 Patient Selection and Counseling

6.1 Patient Selection

Patient selection should be performed by the multi-disciplinary heart team. Use of the SAPIEN M3 system should be considered an option for patients with symptomatic, moderate-severe or severe MR, severe mitral stenosis (MS), or moderate MR with moderate MS. Specific factors that need to be considered include the following:

- Overall medical status, including conditions which might preclude the safety of a percutaneous, transfemoral/transseptal transcatheter procedure including vessel condition, interatrial septum condition, native mitral valve size, end-diastolic and end-systolic ventricular size, and left ventricular outflow tract (LVOT) size unsuitable for the SAPIEN M3 dock and valve based on 3D imaging and screening evaluation.
- Patient's ability to tolerate intraprocedural heparin and anticoagulation/antiplatelet therapy
- Leaflet integrity (e.g., perforation, endocarditis, Barlow's syndrome, etc.)
 - Flail or prolapse located at the commissures

- Flail or prolapse located at P3 leaflet in conjunction with a commissural distance ≥ 42 mm
- Any large non-commissural flail or prolapse
- Characteristics of any pre-existing prosthesis(-es), mitral calcification, and/or sub-valvular anatomy that may interfere with or prevent dock and valve deployment, functionality, or durability.
- Need for cardiac surgery for other reasons
- Renal insufficiency and/or renal replacement therapy
- Life expectancy and considerations for future interventions

6.2 Patient Counseling

Care decisions for a symptomatic patient should be made by the multi-disciplinary heart team and patient in light of all the circumstances presented. The process should use tools for shared decision-making in which patient values, preferences, and associated conditions and co-morbidities, as well as the risks and benefits associated with the treatment options and potential future procedures are considered.

The patient should be counseled on the following information with respect to their disease, expected disease progression, and treatment options:

- An explanation of the underlying heart valve disease and the progressive, unpredictable nature of the condition which will ultimately result in the need for valve repair or replacement.

The patient should be counseled on the following: discuss why medical management, surgery and other transcatheter therapies are not good options, discuss the risks associated with SAPIEN M3 device placement, and discuss other risk/benefit considerations.

- Discussion of the need for blood-thinning medication and/or aspirin as recommended.
- Provide and review the patient brochure

7.0 Potential Adverse Events

The following potential risks are associated with the procedure and device usage including potential access complications associated with standard cardiac catheterization, the potential risks of anesthesia, and the use of angiography.

- Death
- Stroke or neurological dysfunction
- Cardiovascular injury – cardiac structure complications
- Cardiovascular injury – vascular complications
- Cardiovascular injury – access related complications
- Heart failure or low cardiac output / Worsening of heart failure
- Renal insufficiency or renal failure
- Cardiogenic shock
- Cardiac arrest
- Pericardial effusion or cardiac tamponade
- Thromboembolism including air, calcific valve material, or thrombus
- Retroperitoneal bleed
- Arrhythmia
- Hypertension or hypotension
- New or worsening valvular regurgitation
- Bleeding / Hematoma / Hemorrhage
- Hemolysis that may require transfusion or intervention
- Device/Valve thrombosis
- Respiratory insufficiency or respiratory failure
- Paravalvular or transvalvular leak
- Device deterioration (wear, fracture, calcification, or other)
- Reoperation / Reintervention
- Device explants
- Pleural effusion
- LVOT obstruction
- Emergency cardiac surgery
- Conversion to cardiac surgery
- Thoracic bleeding
- Valve stenosis
- Myocardial infarction
- Pulmonary edema
- Transient ischemic attack including clusters
- Device migration, malposition or embolization
- Infection including septicemia and endocarditis
- Allergic reaction to anesthesia, contrast media, or device materials
- Deterioration of native valve (leaflet tear/tearing, leaflet retraction, leaflet thickening, or other)
- Structural valve deterioration (wear, fracture, calcification, leaflet tear/tearing from the stent posts, leaflet retraction, suture line disruption of components of a prosthetic valve, thickening, stenosis)
- Nonstructural valve dysfunction
- Atrial septal defect
- Syncope
- Conduction system defect which may require a permanent pacemaker
- Skin burn
- Mechanical failure of delivery system, and/or accessories

- Valve deployment in an unintended location
- Abnormal lab values (including electrolyte imbalance)
- Angina
- Anemia
- Fever
- Inflammation
- Pain or changes at the access site

8.0 Directions for Use

8.1 Required Equipment

- Standard cardiac catheterization lab equipment
- Fluoroscopy (fixed, mobile, or semi-mobile fluoroscopy systems appropriate for use in percutaneous coronary interventions)
- 3D Transesophageal echocardiography system
- Instrumentation for transseptal access
- Exchange length 0.035" (0.89 mm) extra-stiff guidewires
- Exchange length (≥ 270 cm) pre-shaped stiff TAVR type wire
- ≥ 120 cm pigtail catheter
- Temporary pacemaker and pacing leads
- Sterile heparinized saline (2,000 IU/L) bags (x2)
- Infusion pumps (x2) and infusion pump tubing
- Sterile extension tubing, length > 36 inches (x2)
- Sterile rinsing basins (x6), physiological saline, heparinized saline, diluted radiopaque contrast medium (15 ml contrast: 85 ml heparinized saline)
- SAPIEN M3 valve
- Edwards 23F guide sheath
- SAPIEN M3 dock steerable catheter
- Edwards Commander M delivery system
- Edwards locking syringe
- SAPIEN stabilizer rail system
- SAPIEN M3 crimper
- Edwards reusable accessories

8.2 Device Handling and Preparation

Follow sterile technique during device preparation and implantation.

8.2.1 Prepare the Devices

Step	Procedure
1	Verify expiration date, model number, and visually inspect for breaches in package integrity prior to opening sterile packaging for all devices.
2	Visually inspect all devices and components for damage.

8.2.1.1 Edwards Reusable Accessories

The devices are designed, intended, and distributed for multiple uses. For reusable accessories, refer to the Edwards Reusable Accessories IFU.

8.2.1.2 Edwards 23F Guide Sheath

For Edwards 23F guide sheath device preparation, refer to the Edwards 23F Guide Sheath IFU.

8.2.1.3 SAPIEN M3 Dock Steerable Catheter

Step	Procedure
1	Fill the tray reservoir beneath the dock with only heparinized saline to submerge the dock and sleeve and activate the hydrophilic coating.
2	Attach provided red stopcock to dock handle flush port.
3	Using a 20 cc or larger syringe, flush dock handle flush port with 20 ml heparinized saline. Attach provided white luer cap to release assembly flush port.
4	Using a 20 cc or larger syringe, flush the dock handle flush port with an additional 20 ml heparinized saline. Close the red stopcock to the system.
5	Using a 50 cc or larger syringe, flush steerable catheter flush port with only heparinized saline until heparinized saline comes out of the sleeve lock. Lock sleeve lock and continue flushing until air is removed from sleeve lumen. Close the stopcock to the system.
6	Set up two continuous, heparinized (2,000 IU/L) saline pumps and sterile IV lines infusing at 200 ml/hr each.
7	Connect one, deaired IV line with extension tubing to steerable catheter flush port. Open the stopcock to the system.
8	Connect another, deaired IV line with extension tubing to dock handle flush port. Open the red stopcock to the system. Attach second provided white luer cap to the red stopcock.
9	Align sleeve and dock tip. Lock sleeve lock and leave ¼ turn of dock out of steerable catheter after alignment.
10	Attach provided extension tubing and 50 cc or larger syringe to aspiration adapter and de-air.
11	Insert dock into blue cap of aspiration adapter and tighten cap.
12	Ensure steerable catheter tip is secured in tray and submerged. Perform distal aspiration.

Step	Procedure
13	Loosen blue cap and remove aspiration adapter from dock.
14	Confirm that heparinized saline is flowing out of the steerable catheter tip and the sleeve tip. WARNING: Failure to ensure the heparinized saline drips are each infusing at a rate of 200 ml/hr may result in thrombus formation in the steerable catheter.
15	Retract the sleeved dock fully into steerable catheter. Confirm dock position inside steerable catheter.
16	Lock the dock lock.
17	Confirm all connections are tight, IV pumps are flowing, and all flexes are fully relaxed.

8.2.1.4 Edwards Commander M Delivery System

Step	Procedure
1	Remove all components from the package.
2	Carefully remove the balloon cover from the valve delivery system. Remove the crimp alignment tool and set aside.
3	Flush the valve delivery system with heparinized saline.
4	Place the loader cap onto valve delivery system.
5	Attach a high pressure 3-way stopcock to the balloon inflation port. Partially fill a 50 cc or larger syringe with 15-20 ml diluted contrast medium and attach to the 3-way stopcock.
6	De-air the inflation device with diluted contrast medium. Lock the inflation device and attach to the 3-way stopcock.
7	Close the 3-way stopcock to the inflation device and fully de-air the balloon using a 50 cc or larger syringe. Slowly release the plunger and leave zero-pressure in the system.
8	Ensure 33 ml is in the inflation device. Lock the inflation device.
9	Open stopcock to the inflation device. Remove the 50 cc or larger syringe. CAUTION: Maintain the inflation device provided by Edwards Lifesciences in the locked position until valve deployment to minimize the risk of premature balloon inflation and subsequent improper valve deployment.

8.2.2 SAPIEN M3 Valve Rinsing Procedure

Step	Procedure
1	Before opening the valve jar, verify expiration date, model number, and visually inspect the TagAlert temperature indicator and for breaches in package integrity prior to opening sterile package. Carefully examine for evidence of damage (e.g., a cracked jar or lid, leakage, or broken or missing seals). CAUTION: Valves from containers found to be damaged, leaking, without adequate sterilant, or missing intact seals must not be used for implantation as sterility may be compromised.
2	Set up three (3) sterile bowls with at least 500 ml of sterile physiological saline.
3	Carefully remove the valve/holder assembly from the jar without touching the tissue. Verify the valve serial number with the number on the jar lid and record in the patient information documents. Inspect the valve for any signs of damage to the frame, outer skirt, or tissue. Do not use if damaged.
4	Rinse the valve three times with agitation for a minimum of a minute in each of the three separate bowls filled with physiological saline. Be sure the saline solution completely covers the valve and holder. Ensure the rinse solution in the first and second bowls are not re-used. The valve should be left in the final rinse solution until needed to prevent the tissue from drying. WARNING: Adequate rinsing with physiological saline must be performed before implantation to reduce glutaraldehyde concentration. Failure to rinse the valve in the three bowls with agitation for a minimum of one minute in each bowl may result in glutaraldehyde toxicity. CAUTION: Do not allow the valve to come into contact with the bottom or sides of the rinse bowl during agitation or swirling in the rinse solution. Direct contact between the identification tag and valve is also to be avoided during the rinse procedure. No other objects should be placed in the rinse bowls. The valve should be kept hydrated to prevent the tissue from drying.

8.2.3 Mount and Crimp the SAPIEN M3 Valve onto the Edwards Commander M Delivery System

Step	Procedure
1	Remove the valve from the holder and remove the ID tag.
2	Remove crimper from packaging.
3	Attach the 2-piece crimp stopper to the base of the crimper.
4	With the crimper in the open position, gently place the valve into the crimper aperture. Rotate the handle until the crimper aperture contacts the valve.
5	Insert the valve delivery system coaxially within the valve ensuring that the inflow of the valve (green suture line) is oriented towards the valve delivery system handle.
6	Position the valve on the balloon such that the outflow edge of the valve is proximal to the distal shoulder of the valve delivery system.

Step	Procedure
7	Crimp the valve until it reaches the initial stop located on the 2-piece crimp stopper. Hold for 5 seconds. Remove the valve delivery system from crimper.
8	Place the crimp alignment tool onto stylet tip.
9	Adjust the partially crimped valve until the edge of the valve is touching the crimp alignment tool.
10	Remove crimp alignment tool from stylet while keeping stylet in place.
11	Remove the initial stop from 2-piece crimp stopper, leaving the final stop in place.
12	With the crimper in the open position, gently place the partially crimped valve into the center of the crimper aperture.
13	Fully crimp the valve until it reaches the final crimp stopper. Hold for 5 seconds.
14	Fully crimp two (2) more times, holding 5 seconds for each crimp, for a total of three (3) full crimps.
15	Advance the flex catheter to the edge of the valve by retracting the balloon shaft. Lock the balloon lock.
16	Place the loader over the tapered tip, valve, and flex catheter. Align the distal tip of loader to the distal bump of the balloon. CAUTION: The valve should not remain fully crimped and/or in the loader for over 15 minutes, as leaflet damage may result, and impact valve functionality.
17	Attach the loader cap to the loader, flush the valve delivery system through the flush port to de-air loader. Remove the stylet and flush the guidewire lumen of the valve delivery system. CAUTION: Keep the valve hydrated until ready for implantation to prevent damage to the leaflets which may impact valve functionality. CAUTION: The physician must verify correct orientation of the valve prior to its implantation to prevent the risk of severe patient harm; the green suture (inflow) of the valve should be oriented towards the proximal (handle) end of the valve delivery system.

8.3 SAPIEN M3 Dock and SAPIEN M3 Valve Delivery Procedure

Delivery of the dock and valve should be performed under general anesthesia with hemodynamic monitoring in an operating room, hybrid operating room, or catheterization laboratory with fluoroscopic and 3D echocardiographic imaging capabilities.

CAUTION: Use of excessive contrast media may lead to renal failure. Measure the patient's creatinine level prior to the procedure. Contrast media usage should be monitored.

CAUTION: Excessive device manipulation may result in cardiac structure damage requiring surgical repair or other intervention.

CAUTION: Ensure that a 15 F or larger catheter/device is across the guide sheath seals when aspirating and flushing the guide sheath to reduce the risk of air embolization.

8.3.1 Patient Preparation

Step	Procedure
1	Prior to sterile draping the patient for standard transseptal catheterization via femoral vein access, assemble and position the reusable accessories around the legs of patient, adjusting the height of the platform as needed and maintaining a level surface. Place the cradle on the platform in-line with the intended femoral vein access site. Refer to the Edwards Reusable Accessories IFU. CAUTION: Always maintain a level surface with the reusable platform as tilting the platform could increase air embolization risk. WARNING: The reusable accessories are non-sterile; introduction of the reusable accessories into the sterile field may result in infection.

8.3.2 Baseline Parameters

Step	Procedure
1	Introduce a pacemaker (PM) lead and position appropriately.
2	Set the stimulation parameters to obtain 1:1 capture, and test pacing.
3	Mark the mitral annular plane using a ventriculogram or anatomical landmarks.

8.3.3 Transseptal Access and Edwards 23F Guide Sheath Introduction

Step	Procedure
1	<p>Insert the guide sheath according to the Edwards 23F Guide Sheath IFU and follow additional instructions for use with the SAPIEN M3 system:</p> <ol style="list-style-type: none"> Access the common femoral vein using conventional percutaneous puncture methods. Access the left atrium via transseptal puncture using conventional percutaneous methods and place guidewire in the left atrium. <p>CAUTION: Inappropriate puncture may result in cardiac structure damage, requiring surgical repair or other intervention.</p> <ol style="list-style-type: none"> Administer heparin to maintain the ACT at ≥ 300 sec.
2	<p>Attach the SAPIEN stabilizer rail system onto the reusable accessories.</p> <ol style="list-style-type: none"> Insert the guide sheath and introducer with the flushport oriented away from the operator. Advance until guide sheath tip is across the septum.
3	<p>Secure the guide sheath to the appropriate stabilizer.</p> <ol style="list-style-type: none"> Unlock introducer from guide sheath and slowly retract the introducer and guidewire. With the introducer and wire remaining across the guide sheath seals, aspirate and flush the guide sheath. Remove the introducer and wire slowly.
4	<p>Adjust guide sheath (flex, torque) until the tip of the guide sheath is parallel to the mitral valve plane, as confirmed via fluoroscopy and echocardiography.</p>

8.3.4 SAPIEN M3 Dock Steerable Catheter Positioning

Step	Procedure
1	<p>Confirm that the heparinized saline is flowing out of the steerable catheter tip.</p> <p>WARNING: Failure to ensure a continuous heparinized saline drip is infusing at a rate of 200 ml/hr per pump may result in thrombus formation in the steerable catheter.</p>
2	<p>Insert steerable catheter into guide sheath just past the guide sheath seals.</p>
3	<p>Aspirate and flush guide sheath.</p>
4	<p>Continue advancing the steerable catheter until the tip is positioned at the tip of guide sheath. Secure the steerable catheter to the stabilizer.</p>
5	<p>Under echocardiographic and fluoroscopic guidance, manipulate steerable catheter and guide sheath until steerable catheter tip is in the left ventricle through the medial commissure.</p>
6	<p>Under echocardiographic guidance, verify ventricular access at the medial commissure.</p>

8.3.5 SAPIEN M3 Dock Deployment

Step	Procedure
1	<p>Under echocardiographic and fluoroscopic guidance, advance dock handle to deploy $\frac{1}{4}$ turn of the dock in the ventricle.</p> <p>WARNING: To avoid damage to cardiac structures, ensure that the steerable catheter tip is not pointing directly towards the wall of the left atrium or left ventricle.</p>
2	<p>Under echocardiographic guidance, verify the $\frac{1}{4}$ turn of the dock has not crossed the aortic valve.</p>
3	<p>Manipulate steerable catheter and guide sheath to orient dock trajectory to be parallel with the mitral plane.</p>
4	<p>Advance dock handle to encircle anterior and posterior leaflets with the first functional turn of the dock.</p> <p>CAUTION: Do not apply back flex during encircling as it can result in cardiac structure damage requiring surgical repair or other intervention.</p> <p>WARNING: Do not apply excessive force to the dock. Excessive force applied to the dock can be transferred to the anatomy and may result in cardiac structure damage requiring surgical repair or other intervention.</p> <p>Note: Excessive force is indicated visually by the dock tip not advancing freely (dock loading), the dock diameter enlarging, the dock handle experiencing pushback, or if the dock functional turns are overlapping.</p>
5	<p>Using 2D echocardiography, verify that both mitral leaflets have been captured by the first functional turn of the dock and are moving freely within the dock. Reposition dock as needed.</p>
6	<p>Continue advancing dock handle until the deployment marker band has exited the tip of the steerable catheter. Reengage the dock lock.</p>
7	<p>If the dock functional turns are overlapping, retract the dock and re-attempt encircling. If unable to achieve an acceptable dock orientation, remove the device.</p> <p>CAUTION: Do not apply back flex during encircling as it can result in cardiac structure damage requiring surgical repair or other intervention.</p> <p>WARNING: Do not apply excessive force to the dock. Excessive force applied to the dock can be transferred to the anatomy and may result in cardiac structure damage requiring surgical repair or other intervention.</p>

Step	Procedure
	Note: Excessive force is indicated visually by the dock tip not advancing freely (dock loading), the dock diameter enlarging, the dock handle experiencing pushback, or if the dock functional turns are overlapping.
8	Retract steerable catheter until straddling markers are inside the guide sheath.
9	Apply posterior torque to the steerable catheter. Unflex guide sheath and steerable catheter. Verify that the dock tip and deployment marker band are aligned in the correct position.
10	Pull the sleeve handle to unsleeve the dock. Ensure the sleeve marker band remains on the dock. Relock the sleeve lock.
11	Unlock the dock lock. Hold dock handle in place and retract steerable catheter to be flush with the guide sheath tip. Relock the dock lock.
12	Seat the PVL guard by advancing the sleeve over the dock until the sleeve marker band is between the two (2) seating marker bands.
13	Retract the sleeve handle to completely unsleeve the dock. Relock the sleeve lock.

8.3.6 SAPIEN M3 Dock Release

Step	Procedure
1	If needed, minimize length of guide sheath in the atrium.
2	Advance dock handle until dock handle tip exits the steerable catheter and the guide sheath.
3	Provide suture slack. Translate suture to the tip of the dock. Repeat as necessary.
4	Maneuver the guide sheath to reduce distance from the atrial turn of the dock.
5	Allow the dock to settle over several cardiac cycles to verify that the dock deployment marker band continues to remain in the correct location. WARNING: Incorrect position of dock may result in damage to cardiac structures, paravalvular leak or damage to native mitral leaflets.
6	In commissure-to-commissure view on echo, ensure the dock is less than or equal to 12 mm ventricular from the mitral plane. WARNING: Failure to ensure correct dock depth may result in paravalvular leak and/or cardiac structure damage requiring surgical repair or other intervention.
7	Turn the red stopcock off to the steerable catheter. WARNING: Failure to turn off the flow to the dock handle flush port could result in an air embolism.
8	Open the red suture cover, cut the suture, and remove suture from the steerable catheter. Re-attach the release assembly. CAUTION: Do not cut suture, release the dock, or proceed with remaining steps until dock position and appropriate capture of mitral leaflets has been verified under echocardiography and fluoroscopy. WARNING: Incorrect position of dock may result in paravalvular leak and/or cardiac structure damage requiring surgical repair or other intervention.
9	Unflex steerable catheter. Slowly remove the steerable catheter while leaving guide sheath in place.
10	Prior to removing the steerable catheter, aspirate and flush the guide sheath. Fully remove the steerable catheter.
11	Verify that the dock remains less than or equal to 12 mm ventricular from the mitral plane.

8.3.7 SAPIEN M3 Valve Delivery

Step	Procedure
1	Orient guide sheath tip towards middle of implanted dock.
2	Insert a pigtail (≥ 120 cm in length) with a preloaded 0.035" stiff guide wire into guide sheath and advance through the middle of the implanted dock. Verify guidewire location using both echocardiography and fluoroscopy. WARNING: 3D echocardiographic and fluoroscopic (short-axis view) verification must be used to confirm that the guidewire passes through the middle of the dock and has unrestricted movement. Failure to do so can result in the valve being deployed outside of target location, valve embolization, and/or cardiac structure damage requiring surgical repair or other intervention.
3	Remove the pigtail catheter while maintaining guidewire position in the left ventricle.
4	Confirm valve is crimped in the proper orientation prior to insertion.
5	Insert crimped valve and loader fully into the guide sheath. CAUTION: To prevent possible leaflet damage and possible impact to valve functionality, the valve should not remain in the guide sheath for over 5 minutes.
6	Aspirate and flush guide sheath.
7	Attach 50 cc or larger syringe with > 40 ml heparinized saline. Leave stopcock open to guide sheath. WARNING: Failure to attach a 50 cc or larger syringe with > 40 ml heparinized saline to the guide sheath and leave the stopcock open to the syringe can introduce air into the left atrium.

Step	Procedure
8	Advance crimped valve out of loader.
9	Withdraw and peel away loader.
10	Advance the crimped valve until the valve delivery system tip is at the tip of the guide sheath.
11	Verify the valve is correctly positioned using the valve alignment markers.
12	Close the stopcock, and remove the syringe from the guide sheath.
13	Ensure guide sheath is less than 25% flexed.
14	Advance the valve delivery system until half of the valve exits the guide sheath tip.
15	Apply additional flex (up to 60%) and/or torque to the guide sheath to achieve coaxiality with the dock.
16	Fully advance valve out of guide sheath and position into the dock. Note: There will be a change in force when the valve exits the guide sheath. Advance the valve slowly to ensure that the valve does not interact with the dock. Use care to minimize interaction between the dock and valve during valve positioning.
17	Retract the flex catheter tip to the double markers. Lock the balloon lock. Unflex and retract the guide sheath tip to the double markers.
18	Verify the correct position of the valve with respect to the dock prior to valve deployment.
19	Begin valve deployment: a) Unlock the inflation device provided by Edwards Lifesciences. b) Hold ventilation and begin rapid pacing. c) Deploy the valve using a slow controlled inflation using the entire volume in the inflation device, hold for 3 seconds. d) Deflate the balloon. When the balloon catheter has been completely deflated, turn off the pacemaker and resume ventilation.
20	Prepare for post-dilation: Add 4 ml heparinized saline with contrast (85:15) to the inflation device or balloon via the 3-way stopcock.
21	Verify the correct position of the balloon with respect to the valve.
22	Begin post-dilation: a) Unlock the inflation device provided by Edwards Lifesciences. b) Hold ventilation and begin rapid pacing (if desired). c) Post-dilate the valve by inflating the balloon with the entire volume in the inflation device, hold for 3 seconds. d) Deflate the balloon. When the balloon catheter has been completely deflated, turn off the pacemaker and resume ventilation (if used).
23	Verify that the flex catheter tip is locked over the double markers and guide sheath is partially unflexed. Retract the valve delivery system into the guide sheath.
24	If the valve delivery system is not immediately removed, aspirate and flush guide sheath with 30 ml of heparinized saline.

8.3.8 SAPIEN M3 System Removal

Step	Procedure
1	Remove the valve delivery system from the guide sheath.
2	Remove the guide sheath according to the Edwards 23F Guide Sheath IFU.
3	Close the access site per standard of care.

9.0 How Supplied

STERILE: The SAPIEN M3 valve is supplied sterilized with glutaraldehyde solution. The valve is supplied nonpyrogenic in packaging to which a tamper evident seal has been applied. The SAPIEN M3 dock steerable catheter, Edwards Commander M delivery system, SAPIEN M3 crimper, and SAPIEN stabilizer rail system are ethylene oxide sterilized.

9.1 Storage

The SAPIEN M3 valve must be stored between 10 °C to 25 °C (50 °F to 77 °F). Each valve is shipped in an enclosure containing a temperature indicator to detect exposure of the valve to extreme temperature.

The SAPIEN M3 dock steerable catheter, SAPIEN stabilizer rail system, SAPIEN M3 crimper, Edwards Commander M delivery system, and supporting devices should be stored in a cool, dry place.

10.0 Magnetic Resonance (MR) Safety Information



MRI Safety Information

A person with the SAPIEN M3 valve and dock may be safely scanned at 1.5 T or 3.0 T under the following conditions. Failure to follow these conditions may result in injury.

Device Name	SAPIEN M3 transcatheter mitral valve replacement system
Static Magnetic Field Strength (B0)	1.5 T or 3.0 T
MR Scanner Type	Cylindrical
B0 Field Orientation	Horizontal
Maximum Spatial Field Gradient	40 T/m (4,000 gauss/cm)
RF Excitation	Circularly Polarized (CP)
RF Transmit Coil Type	Integrated Whole Body Transmit Coil
Operating Mode	Normal Operating Mode
Scan Duration	Up to 1 hour of continuous RF (a sequence or back-to-back series/scan without breaks).
Image Artifact	The presence of this implant may produce an image artifact of 1.1 cm. Some manipulation of scan parameters may be needed to compensate for the artifact.

In the presence of other implants, please refer to the MRI safety information for the device(s) prior to MR imaging.

11.0 Patient Information

Patient education brochures are provided to each site and should be given to the patient to inform them of the risks and benefits of the procedure and alternatives in adequate time before the procedure to be read and discussed with their physician. A copy of this brochure may also be obtained from Edwards Lifesciences by calling 1-888-713-1564. Patient implant card request forms are provided with each SAPIEN M3 transcatheter heart valve and each SAPIEN M3 dock. After implantation, all requested information should be completed on these forms. The serial numbers may be found on the packaging of the SAPIEN M3 dock steerable catheter and SAPIEN M3 transcatheter heart valve as well as the identification tag attached to the valve. The original forms should be returned to the Edwards Lifesciences address indicated on the forms. Upon receipt, Edwards Lifesciences will provide identification cards to the patient.

12.0 Recovered Valve and Device Disposal

An explanted SAPIEN M3 valve and/or SAPIEN M3 dock should be placed into a suitable histological fixative such as 10% formalin or 2% glutaraldehyde and returned to the company. Refrigeration is not necessary under these circumstances. Contact Edwards Lifesciences to request an explant kit.

The used devices may be disposed of in the same manner that the hospital waste and biohazardous materials are handled. There are no special or unusual risks related to the disposal of the devices. For disposal of the reusable accessories, refer to the Edwards Reusable Accessories IFU.

13.0 Clinical Studies

13.1 SUMMARY OF PRIMARY CLINICAL STUDY

The ENCIRCLE study was a prospective, single arm, multicenter, pivotal, adaptive design study to evaluate the safety and efficacy of the SAPIEN M3 system in patients with symptomatic moderate-to-severe or severe MR and those with mitral valve dysfunction due to severe MAC who are deemed unsuitable for surgery or TEER therapy. The study included three cohorts, namely, Main Cohort, MAC Registry, and Failed TEER Registry.

The ENCIRCLE study utilized: an independent Case Review Board, which reviewed cases submitted by the investigational sites to determine if the patients being considered were appropriate candidates for the study; an Echocardiography Core Laboratory, which reviewed echocardiography images acquired at baseline and follow-up visits; a Computed Tomography (CT) Core Laboratory, which reviewed CT images acquired at baseline; an independent Data Safety Monitoring Board (DSMB), which was instructed to notify the applicant of any safety or compliance issues; and a Clinical Events Committee (CEC), which was responsible for adjudicating endpoint-related events reported during the study.

Main Cohort

Patients in the Main Cohort were enrolled between June 9, 2020, and October 10, 2023. The database reflected data collected through February 3, 2025, and included 299 patients treated at 56 investigational sites in the US, Australia, Canada, Israel, Netherlands, and the United Kingdom.

Clinical Inclusion and Exclusion Criteria

Patients treated in the Main Cohort were deemed unsuitable for surgery or TEER, and received a SAPIEN M3 valve and dock to treat their moderate-to-severe or severe mitral regurgitation. (complete inclusion and exclusion criteria are available at <https://clinicaltrials.gov/study/NCT04153292>).

Follow-up Schedule

Patients will be followed through 5 years.

Clinical Endpoints

The endpoints analyzed included: all-cause death, heart failure rehospitalization, MR grade, New York Heart Association Class (NYHA) classification, Kansas City Cardiomyopathy Questionnaire (KCCQ) score, MR class, and Left Ventricular End-Diastolic Volume Indexed (LVEDVi).

Mitral Annular Calcification (MAC) Registry

Patients in the MAC Registry were enrolled between January 20, 2022, and March 21, 2024. The database reflected data collected through February 3, 2025, and included 100 patients treated at 36 investigational sites in the US, Australia, Canada, Netherlands, and the United Kingdom.

Clinical Inclusion and Exclusion Criteria

Patients treated in the MAC Registry met all the Main Cohort inclusion criteria in addition to the following modified inclusion criterion: MR ≥ 3+ (if the impact of the calcification to delivery and implantation of the SAPIEN M3 system is uncertain), moderate MR and moderate MS, or severe MS as assessed by the Echo Core Lab.

The exclusion criteria for the MAC Registry were the same as the Main Cohort exclusion criteria.

Follow-up Schedule

Patients will be followed through 5 years.

Clinical Endpoints

The clinical endpoints were the same as those listed above in the ENCIRCLE study Main Cohort. However, no hypothesis testing was performed; only descriptive statistics was performed.

13.2 The ENCIRCLE Study – Main Cohort

A. Accountability of the Main Cohort

At the time of database lock, a total of 299 patients out of 1171 patients enrolled for screening had the procedure started (All-Treated [AT] Population) in the Main Cohort and 287 patients had the study valve implanted (Valve Implant [VI] Population). The most common reason for screening failure was mitral/cardiac anatomy that precluded appropriate delivery and deployment of the dock or valve. Patient accountability through 1 year is summarized in Figure 6.

Figure 6: Patient Accountability Through 1 Year

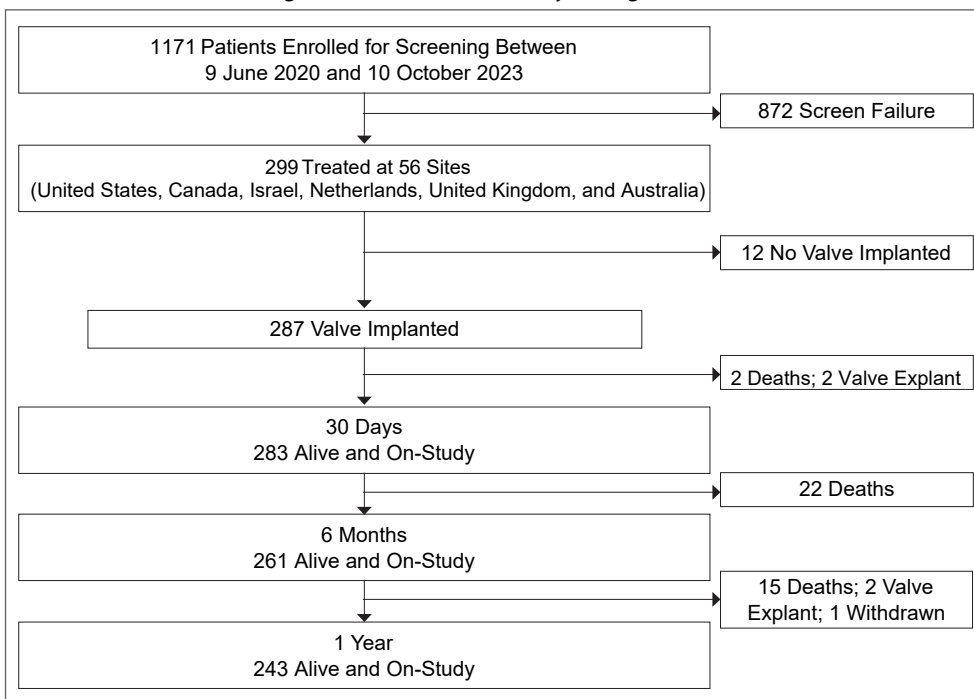

B. Study Population Demographics and Baseline Characteristics

The demographics and baseline characteristics of the study population for the Main Cohort are presented in Table 1, which are typical for a TMVR device study performed in the U.S.

Table 1: Patient Demographics and Baseline Characteristics - Main Cohort (AT Population)

Variable	Summary Statistics*
Age - years	75.5 ± 9.35 (299)
Sex	
Male	50.8% (152/299)
Female	49.2% (147/299)
Hispanic or Latino Ethnicity	3.7% (11/299)
Race	
American Indian or Alaskan Native	1.0% (3/299)
Asian	2.3% (7/299)
Black or African American	9.0% (27/299)
Native Hawaiian or Other Pacific Islander	0.3% (1/299)
White	75.9% (227/299)
Other	3.0% (9/299)
Unknown	8.4% (25/299)
Society of Thoracic Surgeons (STS) score for mitral valve replacement	6.6 ± 4.09 (299)
Society of Thoracic Surgeons (STS) score for mitral valve repair	5.0 ± 4.14 (299)

Variable	Summary Statistics*
New York Heart Association (NYHA) class	
I	0.0% (0/299)
II	28.8% (86/299)
III	67.9% (203/299)
IV	3.3% (10/299)
Chronic kidney disease	41.1% (123/299)
Previous myocardial infarction	30.1% (90/299)
Prior aortic valve intervention	15.7% (47/299)
Prior mitral valve intervention	8.7% (26/298)
Aortic valve disease	41.1% (123/299)
Pulmonic valve disease	15.7% (47/299)
Tricuspid valve disease	63.2% (189/299)
Rheumatic heart disease	4.3% (13/299)
Prior coronary artery bypass grafting (CABG)	30.4% (91/299)
Prior percutaneous coronary intervention (PCI)	35.5% (106/299)
Prior stroke	11.7% (35/299)
Peripheral vascular disease (PVD)	15.1% (45/299)
Atrial fibrillation	69.9% (209/299)
Permanent pacemaker or defibrillator	35.8% (107/299)
Cardiac ablation	15.5% (46/297)
Echocardiographic findings (core laboratory transthoracic echocardiogram)	
Mitral valve mean gradient (mmHg)	3.4 ± 1.97 (284)
Left ventricular ejection fraction (LVEF) (%)	48.4 ± 11.96 (299)
Left ventricular end diastolic diameter (cm)	5.5 ± 0.76 (298)
Left ventricular end diastolic volume (mL)	143.7 ± 53.48 (294)
Left ventricular end systolic volume (mL)	76.5 ± 40.33 (294)
Mitral regurgitation etiology	
Primary (degenerative)	35.4% (105/297)
Secondary (functional ventricular)	53.9% (160/297)
Secondary (functional atrial)	4.4% (13/297)
Mixed (functional and degenerative)	6.4% (19/297)
Total mitral regurgitation (MR) degree [†]	
≤ 2+	0.0% (0/299)
3+	52.2% (156/299)
4+	47.8% (143/299)
Presence of mitral annular calcification (MAC)	24.4% (73/299)
*Continuous measures - mean ± SD (n); categorical measures - % (no./total no.).	
†Baseline MR is based on the worse case between transesophageal echocardiogram (TEE) and transthoracic echocardiogram (TTE).	

C. Safety and Effectiveness Results

1. Primary Endpoint

The primary endpoint results are presented in Table 2 and in Figure 7. The composite rate of all-cause death and heart failure rehospitalization at 1 year was 25.2% with a one-sided 97.5% upper confidence bound of 30.6%, which is less than the performance goal of 45% ($p < 0.001$). Therefore, the primary endpoint was met.

**Table 2: Primary Endpoint Analysis - Main Cohort
(AT Population)**

Event	Event Rate*	95% CI [†]	Performance Goal	P-value [‡]	Primary Endpoint Status
All-cause death or heart failure rehospitalization at 1 year	25.2% (73)	[20.6%, 30.6%]	45%	< 0.001	Endpoint met
All-cause death	13.9% (40)	[10.4%, 18.5%]	-	-	-
Heart failure rehospitalization	16.7% (47)	[12.8%, 21.6%]	-	-	-

CI: confidence interval.

*Kaplan-Meier estimate % (no. of patients with the event).

†CI was calculated based on a one-sided significance level of 0.025 using Greenwood's formula.

‡The p-value was calculated using the Wald Test with Greenwood's formula.

Figure 7: Kaplan-Meier Curve for All-Cause Death or Heart Failure Rehospitalization Through 1 Year - Main Cohort (AT Population)

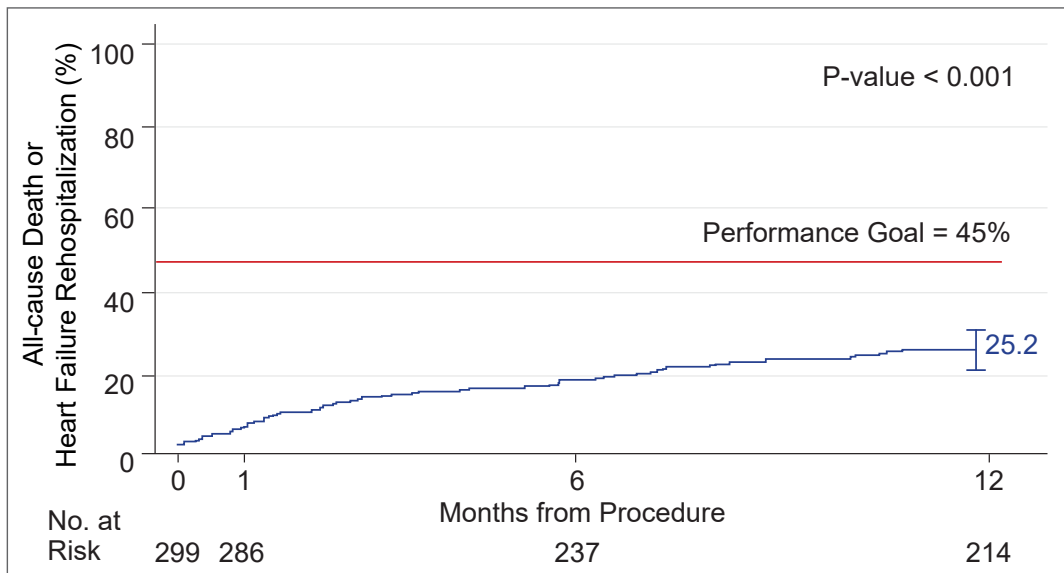

The times to first event for each of the primary endpoint components are shown in Figure 8 and Figure 9.

Figure 8: All-Cause Death Through 1 Year - Main Cohort (AT Population)

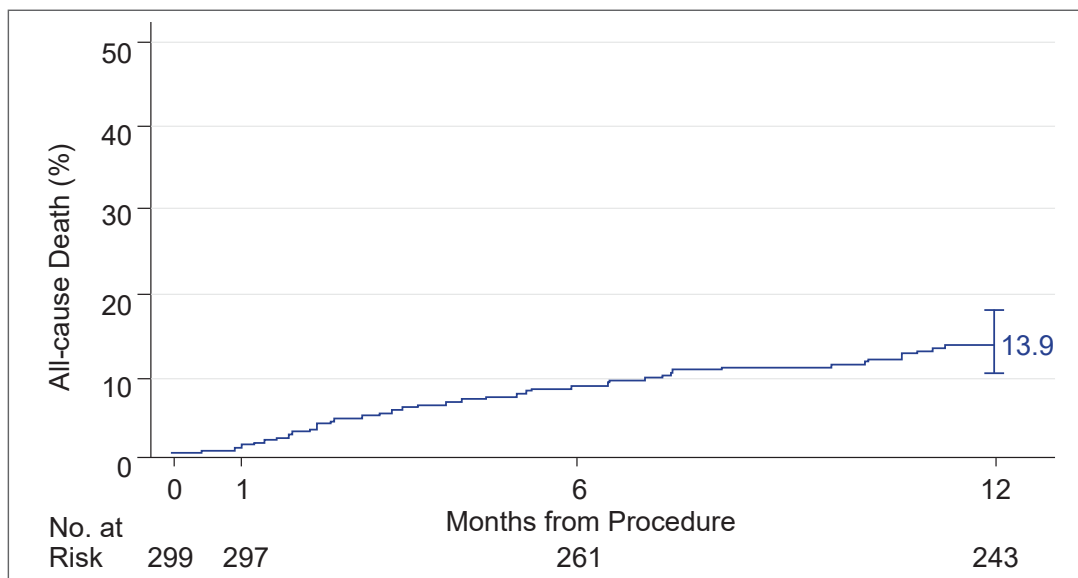

**Figure 9: Heart Failure Rehospitalization Through 1 Year - Main Cohort
(AT Population)**

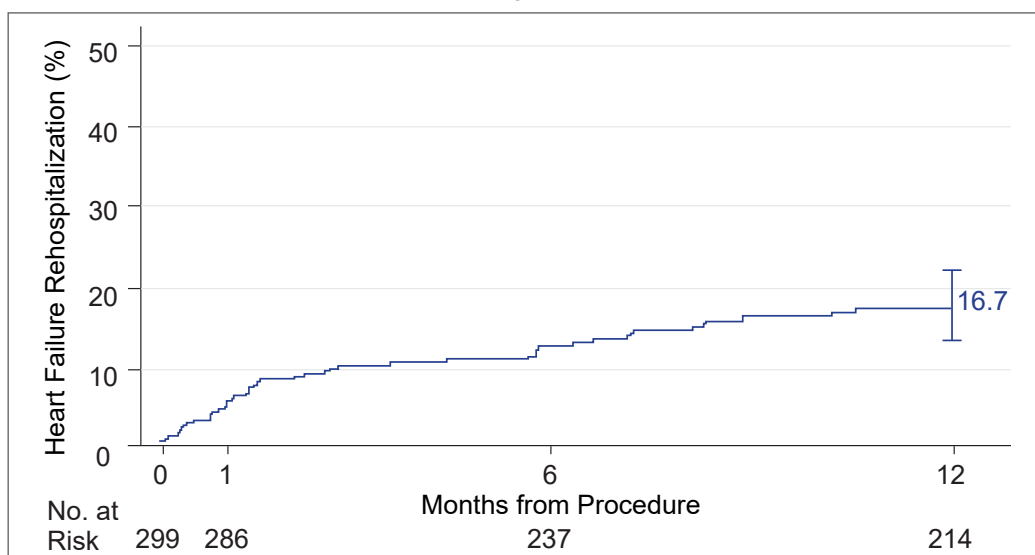

2. Secondary Endpoints

Since the primary endpoint was met, paired analyses from baseline for the four prespecified non-hierarchical, hypothesis-driven secondary endpoints were tested for statistical significance. All four secondary endpoints were met, as shown in Table 3.

**Table 3: Results of Secondary Endpoints - Main Cohort
(VI Population)**

No.	Endpoint	Summary Statistics*	P-value	Test Result
1	Improvement in MR severity at 1 year over baseline	100.0% (232/232)	< 0.001 [†]	Pass
2	Improvement in NYHA class at 1 year over baseline	73.4% (171/233)	< 0.001 [†]	Pass
3	Improvement in KCCQ summary score at 1 year over baseline	18.4 ± 1.68 (229)	< 0.001 [‡]	Pass
4	Improvement in LVEDVi at 1 year over baseline (mL/m ²)	-4.7 ± 1.39 (208)	< 0.001 [‡]	Pass

MR: mitral regurgitation; NYHA: New York Heart Association; KCCQ: Kansas City Cardiomyopathy Questionnaire; LVEDVi: left ventricular end-diastolic volume index.

*Categorical measures - % (no. / total no.); continuous measures - Mean ± SE (n).

[†]P-value was from sign test.

[‡]P-value was from paired t-test. The Hochberg procedure was used for multiplicity adjustment to control family-wise type I error.

3. Descriptive Endpoints

KCCQ

The KCCQ overall summary scores by visit are presented in Figure 10. The mean score increased from 57.0 at baseline to 75.0 at 1 year post-procedure.

**Figure 10: KCCQ Overall Summary Score by Visit - Main Cohort
(VI Population)**

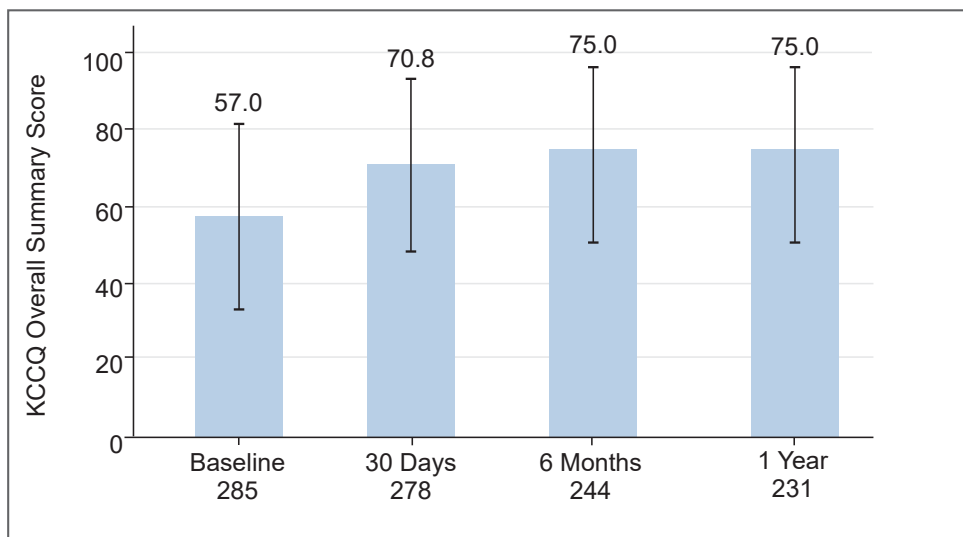

Note: The error bars represent standard deviations.

EQ-5D-5L

The EQ-5D-5L Visual Analogue Scale (VAS) scores are presented in Figure 11. The mean score was 64.8 at baseline and 73.5 at 1 year post-procedure.

**Figure 11: EQ-5D-5L Visual Analog Score by Visit - Main Cohort
(VI Population)**

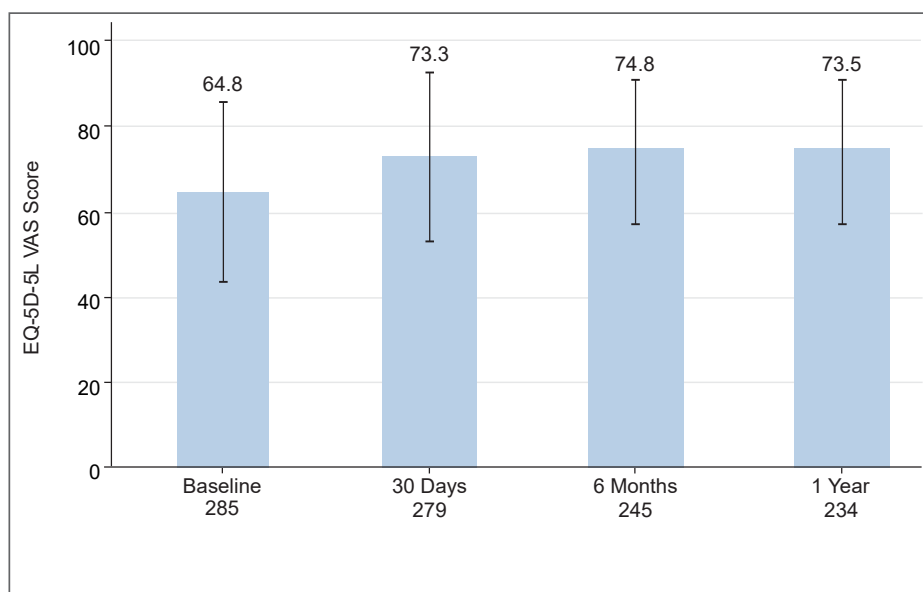

Note: The error bars represent standard deviations.

NYHA Functional Class

The NYHA classifications by visit are presented in Figure 12. At 1 year post-procedure, 87.9% of patients were in NYHA class I/II compared to 28.6% at baseline.

Figure 12: NYHA Functional Class by Visit - Main Cohort

(VI Population)

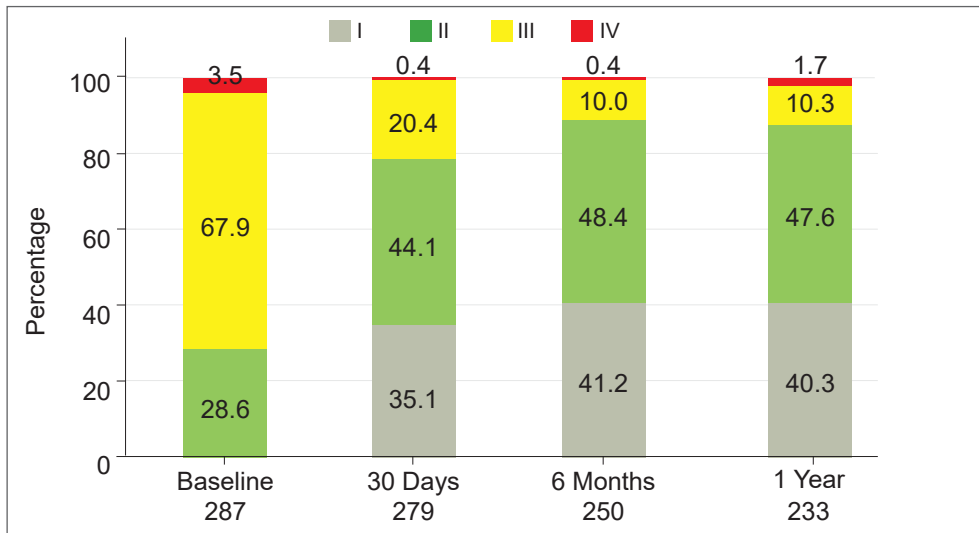

6MWT Distance

The results for the 6MWT distance are presented in Figure 13. The mean walk distance increased from 239.6 meters at baseline to 259.4 meters at 1 year post-procedure.

Figure 13: 6MWT Distance by Visit - Main Cohort

(VI Population)

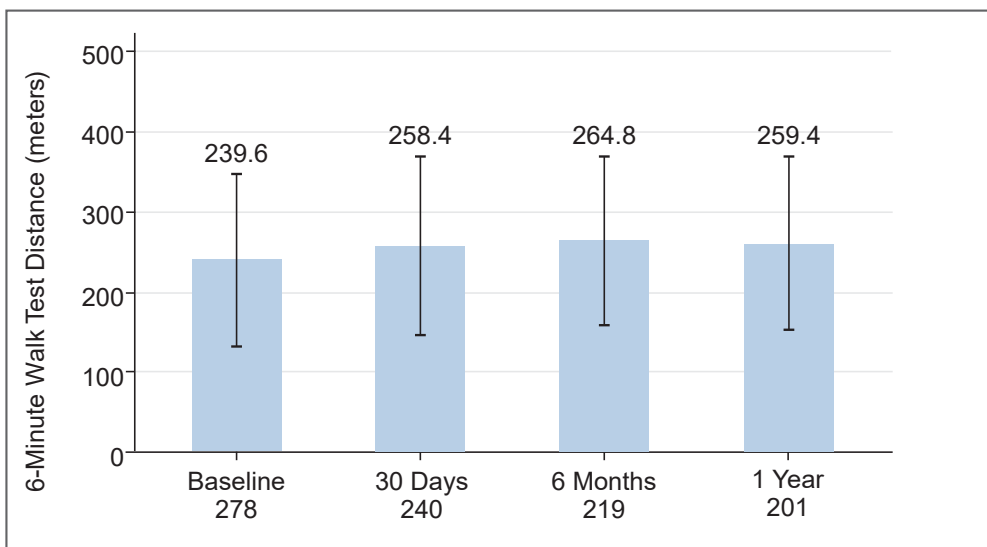

Note: The error bars represent standard deviations.

MR Severity

MR severity by visit is shown in Figure 14. MR reduction to $\leq 1+$ was achieved in 95.7% of patients at 1 year.

**Figure 14: MR Severity by Visit - Main Cohort
(VI Population)**

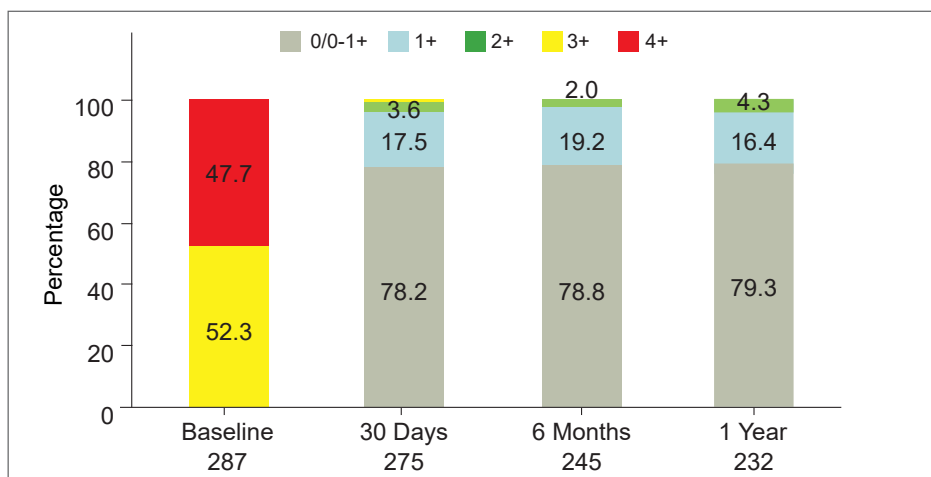

Note: The worst case between transesophageal echocardiogram and transthoracic echocardiogram results was used as the baseline and trans-thoracic echocardiogram results were used for all other visits.

4. Adverse Events

The Kaplan-Meier estimates of CEC-adjudicated serious adverse events and other adverse events of clinical interest through 1 year are presented in Table 4.

**Table 4: CEC-Adjudicated Adverse Events Through 1 Year - Main Cohort
(AT Population)**

Event	Kaplan Meier Estimate*		
	30 Days	6 Months	1 Year
All-cause death	0.7% (2, 2)	8.7% (25, 25)	13.9% (40, 40)
Cardiovascular	0.7% (2, 2)	6.3% (18, 18)	8.9% (25, 25)
Non-cardiovascular	0.0% (0, 0)	2.5% (7, 7)	5.6% (15, 15)
Heart failure rehospitalization	4.0% (13, 12)	12.2% (43, 35)	16.7% (63, 47)
All stroke	2.7% (8, 8)	6.3% (18, 18)	9.3% (29, 26)
Disabling	1.7% (5, 5)	2.4% (7, 7)	3.9% (13, 11)
Non-disabling	1.0% (3, 3)	3.9% (11, 11)	5.5% (16, 15)
Acute kidney injury Stage 2	0.7% (2, 2)	---	---
Acute kidney injury Stage 3	2.3% (7, 7)	---	---
New-onset atrial fibrillation	7.9% (7, 7)	11.5% (10, 10)	11.5% (10, 10)
New permanent pacemaker implantation	2.6% (5, 5)	4.9% (9, 9)	5.5% (10, 10)
Life-threatening bleeding	3.7% (11, 11)	3.7% (11, 11)	6.8% (19, 19)
Fatal bleeding	0.0% (0, 0)	0.8% (2, 2)	1.1% (3, 3)
Hemolysis [†]	3.0% (9, 9)	3.7% (11, 11)	3.7% (11, 11)
Hemolytic anemia [‡]	4.3% (13, 13)	7.1% (21, 21)	7.1% (21, 21)
Valve thrombosis [§]	4.4% (13, 13)	9.3% (27, 27)	12.9% (36, 36)
Clinically significant leaflet thrombosis	2.3% (7, 7)	5.5% (16, 16)	6.7% (19, 19)
Dock fracture	0.0% (0, 0)	0.0% (0, 0)	0.0% (0, 0)
Dock migration	0.0% (0, 0)	0.0% (0, 0)	0.0% (0, 0)
Valve embolization	0.0% (0, 0)	0.0% (0, 0)	0.0% (0, 0)
Valve fracture	0.0% (0, 0)	0.0% (0, 0)	0.0% (0, 0)
Valve migration	0.0% (0, 0)	0.0% (0, 0)	0.0% (0, 0)
Clinically significant TMVR-related LVOT obstruction	0.0% (0, 0)	0.0% (0, 0)	0.0% (0, 0)
Mitral valve reintervention	2.3% (8, 7)	4.5% (14, 13)	6.4% (19, 18)
Balloon mitral valvuloplasty	0.0% (0, 0)	0.0% (0, 0)	0.4% (1, 1)
Percutaneous paravalvular leak closure	1.3% (5, 4)	3.1% (10, 9)	3.5% (11, 10)
Surgical mitral valve replacement	0.7% (2, 2)	0.7% (2, 2)	1.5% (4, 4)
Valve in valve	0.0% (0, 0)	0.4% (1, 1)	1.2% (3, 3)
Other	0.3% (1, 1)	0.3% (1, 1)	0.3% (1, 1)

Event	Kaplan Meier Estimate*		
	30 Days	6 Months	1 Year
Myocardial infarction	0.7% (2, 2)	1.8% (5, 5)	1.8% (5, 5)
Transient ischemic attack (TIA)	0.7% (2, 2)	1.0% (3, 3)	2.2% (6, 6)
Study device related endocarditis	0.0% (0, 0)	0.7% (2, 2)	1.1% (3, 3)
Major vascular complication	0.7% (2, 2)	0.7% (2, 2)	0.7% (2, 2)
Major access site complication	2.3% (7, 7)	4.1% (12, 12)	4.9% (14, 14)
Atrial septal defect	2.3% (7, 7)	4.1% (12, 12)	4.9% (14, 14)
Major cardiac structure complication	2.3% (7, 7)	2.7% (8, 8)	2.7% (8, 8)

TMVR: transcatheter mitral valve replacement; LVOT: left ventricular outflow obstruction.
 *Kaplan-Meier estimate - % (no. events, no. of patients with the event).
 †Hemolysis: the presence of a paravalvular leak on echocardiogram plus acute decrease in haptoglobin levels and/or increase in serum lactate dehydrogenase (LDH) levels and/or standard blood examinations supporting hemolysis with associated anemia and diagnosis of hemolysis due to prosthetic valve, not requiring transfusion.
 ‡Hemolytic anemia: hemolysis requiring transfusion or intervention (or need for intervention) on the mitral valve.
 §Inadequate anticoagulation (no anticoagulation, gap in treatment, or subtherapeutic) appeared to be a factor in the occurrence of device thrombosis regardless of the type of anticoagulation prescribed. The observed valve thrombosis rate at 1 year was 7.0% in patients with adequate anticoagulation and 20.9% in those with inadequate anticoagulation.
 ||Only interventions after procedure.

5. Subgroup Analyses

The primary endpoint results by gender and by MR etiology are presented in Table 5 and Table 6, respectively. The primary endpoint results were consistent when analyzed by gender and MR etiology.

**Table 5: Primary Endpoint Analysis by Gender - Main Cohort
(AT Population)**

Event	Summary Statistics*	
	Male (N=152)	Female (N=147)
All-cause death or heart failure rehospitalization at 1 year	25.2% (37)	25.2% (36)
All-cause death	14.5% (21)	13.4% (19)
Heart failure rehospitalization	16.9% (24)	16.4% (23)

*Kaplan-Meier estimate % (no. of patients with the event).

**Table 6: Primary Endpoint Analysis by MR Etiology - Main Cohort
(AT Population)**

Event	Summary Statistics*	
	Primary MR (N=105)	Secondary MR (N=160)
All-cause death or heart failure rehospitalization at 1 year	26.3% (26)	25.5% (40)
All-cause death	15.3% (15)	12.9% (20)
Heart failure rehospitalization	17.8% (17)	17.1% (26)

MR: mitral regurgitation.
 *Kaplan-Meier estimate % (no. of patients with the event).

The primary endpoint result by race is shown in Table 7.

**Table 7: Primary Endpoint Result by Race - Main Cohort
(AT Population)**

Race	All-cause Death or Heart Failure Rehospitalization at 1 Year* (N=299)
White	55/227
Black or African American	9/27
Native Hawaiian or Other Pacific Islander	0/1
Asian	1/7
American Indian or Alaskan Native	0/3

Race	All-cause Death or Heart Failure Rehospitalization at 1 Year* (N=299)
Other	4/9
Unknown	4/25

*no. of patients with events/total no. patients in the subgroup.

6. Other Study Observations

Procedural Information

The procedural data are presented in Table 8.

**Table 8: Procedure Data - Main Cohort
(AT Population)**

Variable	Summary Statistics*
Procedure time (min) [†]	127.0 ± 47.13 (293)
Total fluoroscopy time (min)	51.9 ± 24.61 (297)
Dock deployment time (min) [‡]	65.9 ± 35.04 (291)
Multiple valve implant	0.0% (0/287)
Percutaneous paravalvular leak closure	5.0% (15/299)
Procedure aborted	4.0% (12/299)
Conversion to surgery	0.0% (0/287)

*Continuous measures - mean ± SD (n); categorical measures - % (no./total no.).
[†]Defined as the time from femoral vein access to guide sheath removal.
[‡]Defined as the time from steerable catheter insertion to removal.

Index Hospitalization

The index hospitalization information is presented in Table 9.

**Table 9: Index Hospitalization Information - Main Cohort
(VI Population)**

Variable	Summary Statistics*
Index hospitalization stay (days) [†]	2.9 ± 3.55 (286)
Intensive care stay (days)	0.7 ± 1.47 (286)
In-hospital death	0.3% (1/287)

*Continuous measures - mean ± SD (total no.); categorical measures - % (no./total no.).
[†]Index hospitalization stay excludes in-hospital deaths.

Additional Echocardiographic Data

Additional echocardiographic data through 1 year are presented in Table 10, which show a generally positive trend in left ventricular remodeling.

**Table 10: Additional Echocardiographic Data - Main Cohort
(VI Population)**

Parameter	Summary Statistics*			
	Baseline	30-days	6-months	1-year
LV end diastolic volume index (mL/m ²)	75.0 ± 24.94 (282)	70.2 ± 24.33 (254)	71.5 ± 24.53 (221)	70.6 ± 26.69 (213)
LV end diastolic diameter (cm)	5.5 ± 0.04 (286)	5.3 ± 0.05 (261)	5.4 ± 0.05 (232)	5.3 ± 0.05 (228)
LV ejection fraction (%)	48.4 ± 11.95 (287)	38.7 ± 11.56 (276)	40.5 ± 12.32 (246)	41.3 ± 12.16 (235)
LV end diastolic volume (mL)	143.4 ± 53.71 (282)	133.6 ± 52.96 (254)	136.8 ± 53.40 (221)	135.6 ± 56.17 (213)
LV end systolic volume (mL)	76.7 ± 40.82 (282)	84.5 ± 43.85 (252)	84.7 ± 46.26 (216)	83.6 ± 48.55 (207)
Transmitral antegrade mean gradient (mmHg)	3.4 ± 1.96 (272)	5.4 ± 2.11 (274)	5.3 ± 2.28 (246)	5.5 ± 2.22 (233)
Stroke volume index (mL/m ²)	28.8 ± 8.73 (278)	35.9 ± 13.65 (268)	37.1 ± 14.22 (241)	37.8 ± 14.87 (227)
Cardiac output index (L/min/m ²)	2.1 ± 0.60 (278)	2.5 ± 0.86 (268)	2.5 ± 0.88 (241)	2.5 ± 0.90 (227)

Parameter	Summary Statistics*			
	Baseline	30-days	6-months	1-year
LV: left ventricular.				
*Continuous measures - mean \pm SD (n).				

Correlation Between KCCQ and Other Outcomes .

Post hoc analyses were performed to explore the correlation between KCCQ overall summary score change from baseline and heart failure rehospitalization, NYHA functional class, MR severity, and 6MWT distance. The results are shown in Figure 15 through Figure 18, which show a correlation between higher KCCQ overall summary score and absence of heart failure hospitalization, lower NYHA functional class, lower grade of MR severity, and larger improvement in 6MWT distance at 1 year.

Figure 15: KCCQ Overall Summary Score vs. Heart Failure Rehospitalization at 1 Year - Main Cohort (AT Population)

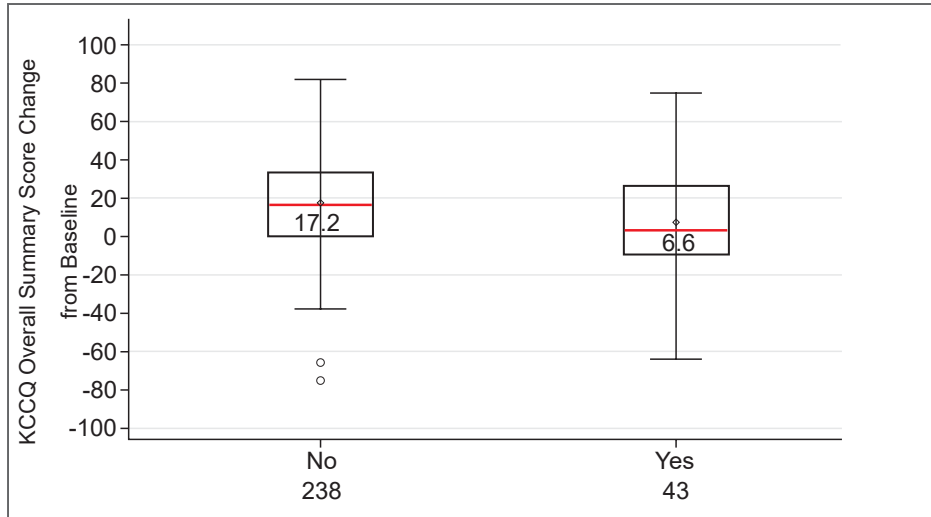
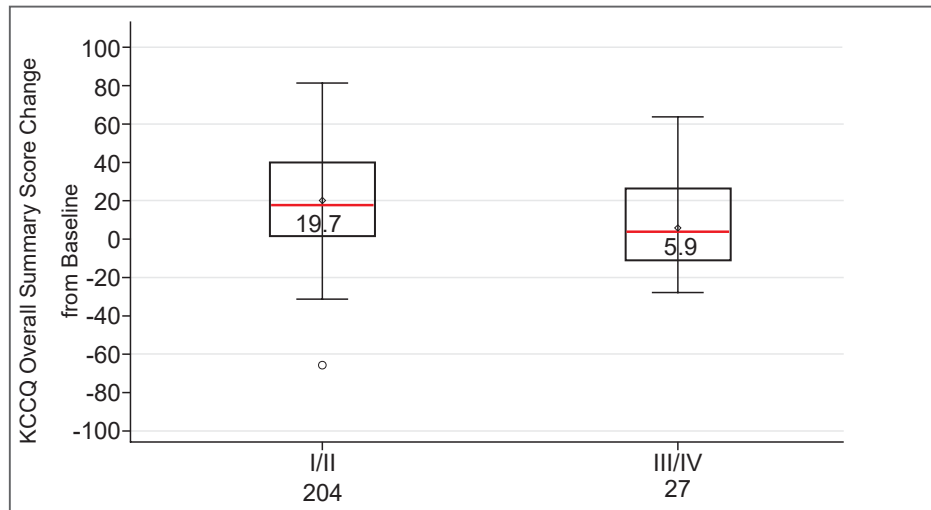
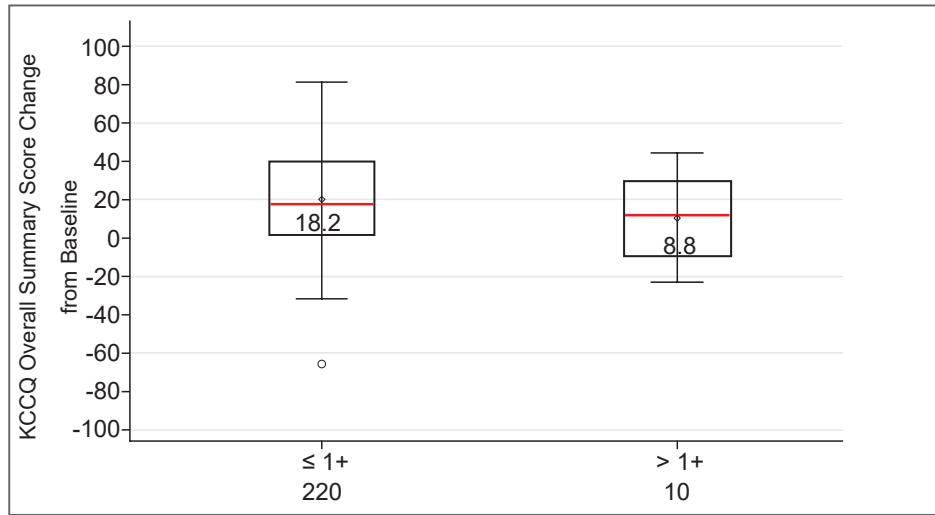

Figure 16: KCCQ Overall Summary Score vs. NYHA Functional Class at 1 Year - Main Cohort (AT Population)



**Figure 17: KCCQ Overall Summary Score vs. MR Severity at 1 Year - Main Cohort
(AT Population)**



**Figure 18: KCCQ Overall Summary Score Change vs. 6MWT Distance Change at 1 Year - Main Cohort
(AT Population)**

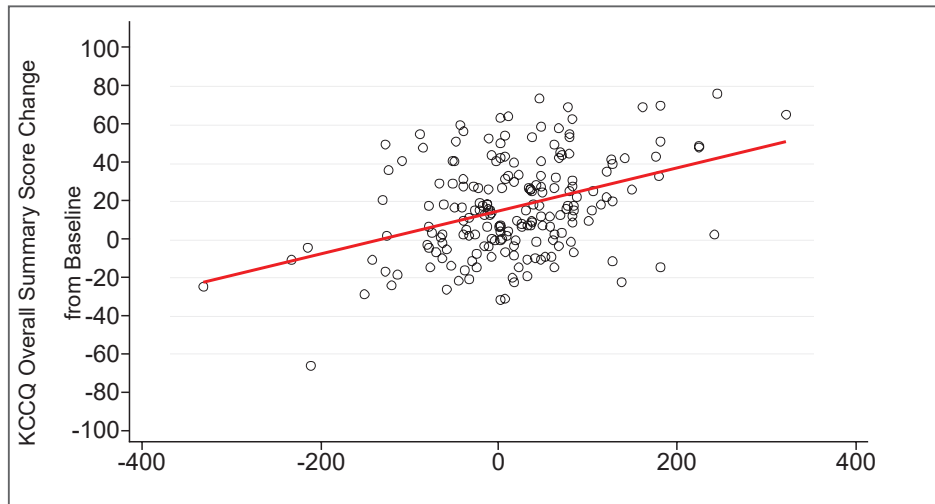

13.3 The ENCIRCLE Study – Mitral Annular Calcification (MAC) Registry

A. Accountability of the MAC Registry

At the time of database lock, a total of 100 patients out of 364 patients enrolled for screening had the procedure started (All-Treated [AT] Population) in the MAC Registry and 93 patients had the study valve implanted (Valve Implant [VI] Population). Patient accountability through 1 year is summarized in Figure 19.

Figure 19: Patient Accountability Through 1 Year - MAC Registry

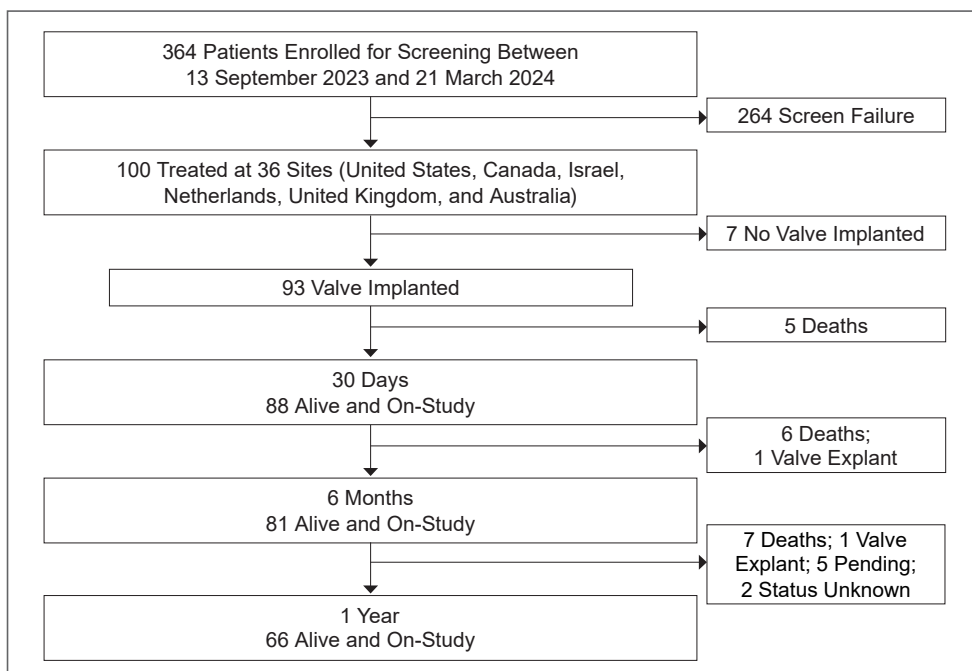

B. Study Population Demographics and Baseline Characteristics

The demographics and baseline characteristics of the study population are presented in Table 11, which are typical for a TMVR device study in patients with severe MAC performed in the U.S.

**Table 11: Patient Demographics and Baseline Characteristics - MAC Registry
(AT Population)**

Demographics and Baseline Characteristics	Summary Statistics*
Age - years	76.1 ± 9.22 (100)
Sex	
Male	51.0% (51/100)
Female	49.0% (49/100)
Hispanic or Latino Ethnicity	3.0% (3/100)
Race	
American Indian or Alaskan Native	0.0% (0/100)
Asian	2.0% (2/100)
Black or African American	1.0% (1/100)
Native Hawaiian or Other Pacific Islander	0.0% (0/100)
White	85.0% (85/100)
Other	2.0% (2/100)
Unknown	10.0% (10/100)
Society of Thoracic Surgeons (STS) score for mitral valve replacement	8.4 ± 4.90 (100)
Society of Thoracic Surgeons (STS) score for mitral valve repair	6.0 ± 5.45 (100)
New York Heart Association (NYHA) class	
I	0.0% (0/100)
II	27.0% (27/100)
III	69.0% (69/100)
IV	4.0% (4/100)
Chronic kidney disease	42.0% (42/100)
Previous myocardial infarction	25.0% (25/100)
Prior aortic valve intervention	48.0% (48/100)
Prior mitral valve intervention	3.0% (3/100)
Aortic valve disease	71.0% (71/100)
Pulmonic valve disease	11.0% (11/100)

Demographics and Baseline Characteristics	Summary Statistics*
Tricuspid valve disease	69.0% (69/100)
Rheumatic heart disease	7.0% (7/100)
Prior coronary artery bypass grafting (CABG)	28.0% (28/100)
Prior percutaneous coronary intervention (PCI)	38.0% (38/100)
Prior stroke	14.0% (14/100)
Peripheral vascular disease (PVD)	17.0% (17/100)
Atrial fibrillation	66.0% (66/100)
Permanent pacemaker or defibrillator	38.0% (38/100)
Cardiac ablation	18.0% (18/100)
Echocardiographic findings (core laboratory transthoracic echocardiogram)	
Mitral valve mean gradient (mmHg)	6.1 ± 3.27 (100)
Left ventricular ejection fraction (LVEF) (%)	54.6 ± 10.53 (100)
Left ventricular end diastolic diameter (cm)	4.9 ± 0.66 (100)
Left ventricular end diastolic volume (mL)	112.2 ± 44.30 (97)
Left ventricular end systolic volume (mL)	52.0 ± 27.77 (97)
Mitral regurgitation etiology	
Primary (degenerative)	77.0% (77/100)
Secondary (functional ventricular)	15.0% (15/100)
Secondary (functional atrial)	0.0% (0/100)
Mixed (functional and degenerative)	8.0% (8/100)
Total mitral regurgitation (MR) degree [†]	
≥ 3+	71.0% (71/100)
=2+	19.0% (19/100)
=1+ with severe stenosis	10.0% (10/100)
Presence of mitral annular calcification (MAC)	98.0% (98/100)
*Continuous measures - mean ± SD (n); categorical measures - % (no./total no.).	
†Baseline MR is based on the worse case between transesophageal echocardiogram and transthoracic echocardiogram.	

The CT Core Laboratory conducted calcium evaluation to characterize the calcium morphology at each of the six mitral segments (A1, A2, and A3 for the anterior annulus and leaflet, and P1, P2, and P3 for the posterior annulus leaflet). The results are presented in Table 12.

**Table 12: Annular and Leaflet Calcifications - MAC Registry
(AT Population)**

Calcium Characterization	Summary Statistics*
<i>Annular calcifications</i>	
A1	
Grade	
None	40.0% (40/100)
Mild	15.0% (15/100)
Moderate	23.0% (23/100)
Severe	22.0% (22/100)
Spur	34.0% (34/100)
A2	
Grade	
None	66.0% (66/100)
Mild	8.0% (8/100)
Moderate	11.0% (11/100)
Severe	15.0% (15/100)
Spur	39.0% (39/100)
A3	
Grade	
None	37.0% (37/100)
Mild	19.0% (19/100)
Moderate	19.0% (19/100)
Severe	25.0% (25/100)
Spur	40.0% (40/100)
P1	

Calcium Characterization	Summary Statistics*
Grade	
None	23.0% (23/100)
Mild	16.0% (16/100)
Moderate	26.0% (26/100)
Severe	35.0% (35/100)
Spur	9.0% (9/100)
P2	
Grade	
None	13.0% (13/100)
Mild	13.0% (13/100)
Moderate	22.0% (22/100)
Severe	52.0% (52/100)
Spur	20.0% (20/100)
P3	
Grade	
None	19.0% (19/100)
Mild	14.0% (14/100)
Moderate	20.0% (20/100)
Severe	47.0% (47/100)
Spur	15.0% (15/100)
<i>Leaflet calcifications</i>	
A1	
None	48.0% (48/100)
Mild	13.0% (13/100)
Pronounced	39.0% (39/100)
A2	
None	49.0% (49/100)
Mild	5.0% (5/100)
Pronounced	46.0% (46/100)
A3	
None	39.0% (39/100)
Mild	14.0% (14/100)
Pronounced	47.0% (47/100)
P1	
None	69.0% (69/100)
Mild	19.0% (19/100)
Pronounced	12.0% (12/100)
P2	
None	48.0% (48/100)
Mild	25.0% (25/100)
Pronounced	27.0% (27/100)
P3	
None	61.0% (61/100)
Mild	16.0% (16/100)
Pronounced	23.0% (23/100)
*Categorical measures - % (no./total no.).	

C. Safety and Effectiveness Results

1. Primary Endpoint

The primary endpoint results are presented in Table 13 and in Figure 20. The composite rate of all-cause death and heart failure rehospitalization at 1 year was 34.1%.

**Table 13: Primary Endpoint Analysis - MAC Registry
(AT Population)**

Event	Summary Statistics*
All-cause death or heart failure rehospitalization at 1 year	34.1% (32)
All-cause death	21.7% (20)
Heart failure rehospitalization	19.6% (17)

*Kaplan-Meier estimate % (no. of patients with the event).

**Figure 20: Kaplan-Meier Curve for All-Cause Death or Heart Failure Rehospitalization Through 1 Year - MAC Registry
(AT Population)**

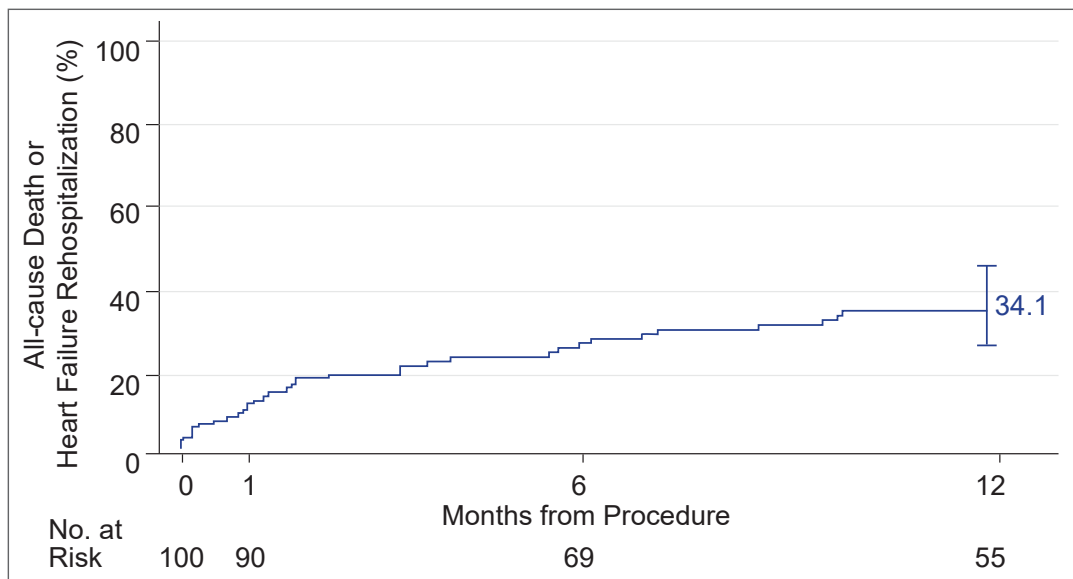

The times to first event for each of the primary endpoint components are shown in Figure 21 and Figure 22.

**Figure 21: All-Cause Death Through 1 Year - MAC Registry
(AT Population)**

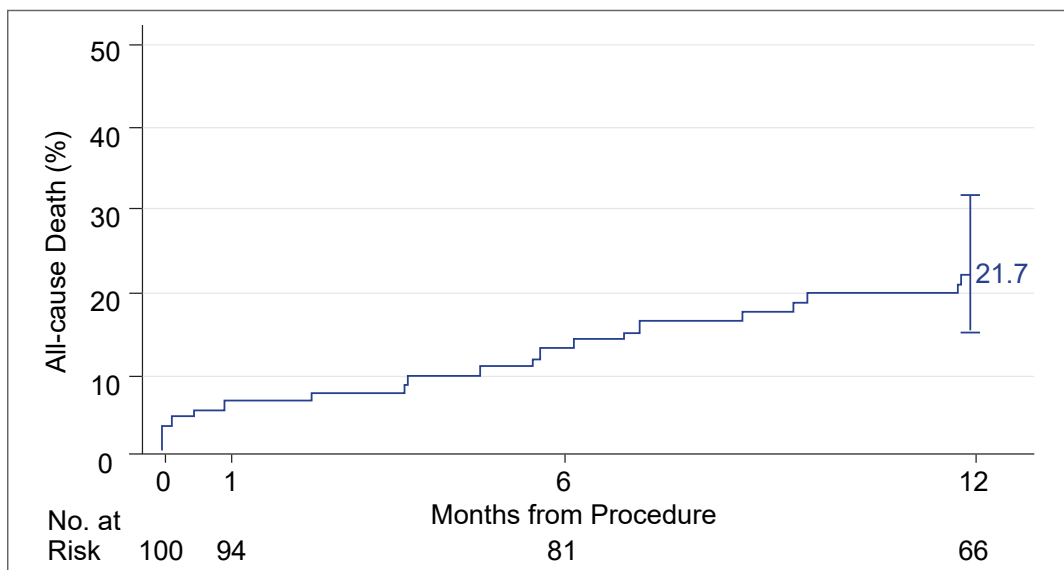

**Figure 22: Heart Failure Rehospitalization Through 1 Year - MAC Registry
(AT Population)**

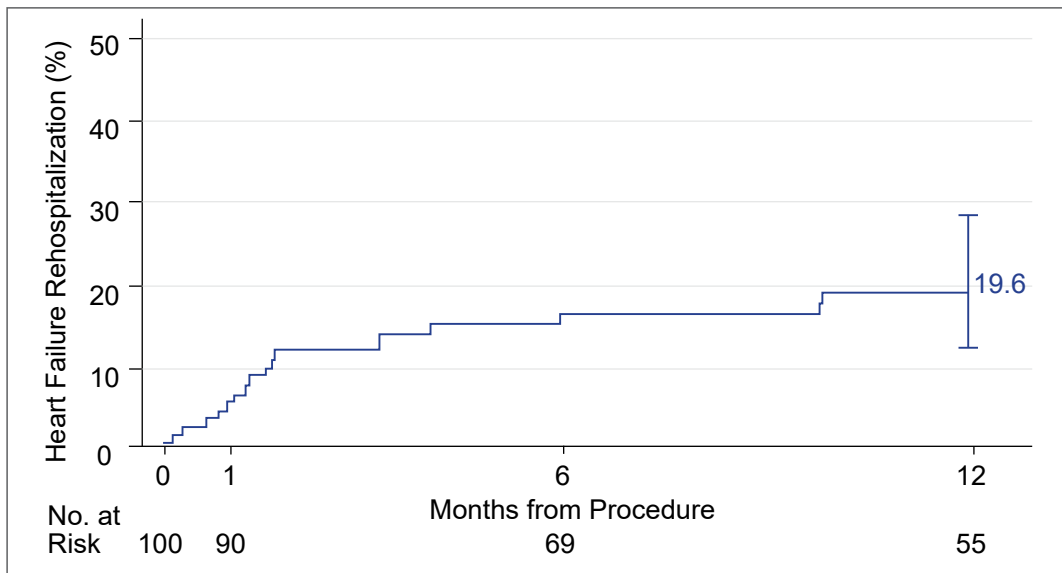

2. Secondary Endpoints

The paired results of the four secondary endpoints are presented in Table 14.

**Table 14: Secondary Endpoints - MAC Registry
(VI Population)**

No.	Endpoint*	Summary Statistics*
1	Improvement in MR severity at 1 year over baseline	96.3% (52/54)
2	Improvement in NYHA class at 1 year over baseline	65.5% (38/58)
3	Improvement in KCCQ summary score at 1 year over baseline	19.7 ± 2.87 (61)
4	Improvement in LVEDVi at 1 year over baseline (mL/m ²)	-2.7 ± 2.53 (48)

MR: mitral regurgitation; NYHA: New York Heart Association; KCCQ: Kansas City Cardiomyopathy Questionnaire; LVEDVi: left ventricular end-diastolic volume index.
*Categorical measures - % (no. / total no.); continuous measures - mean ± SE (n). All results were from paired analyses.

3. Descriptive Endpoints

KCCQ

The KCCQ overall summary scores by visit are presented in Figure 23. The mean score increased from 52.9 at baseline to 72.6 at 1 year post-procedure.

**Figure 23: KCCQ Overall Summary Score by Visit - MAC Registry
(VI Population)**

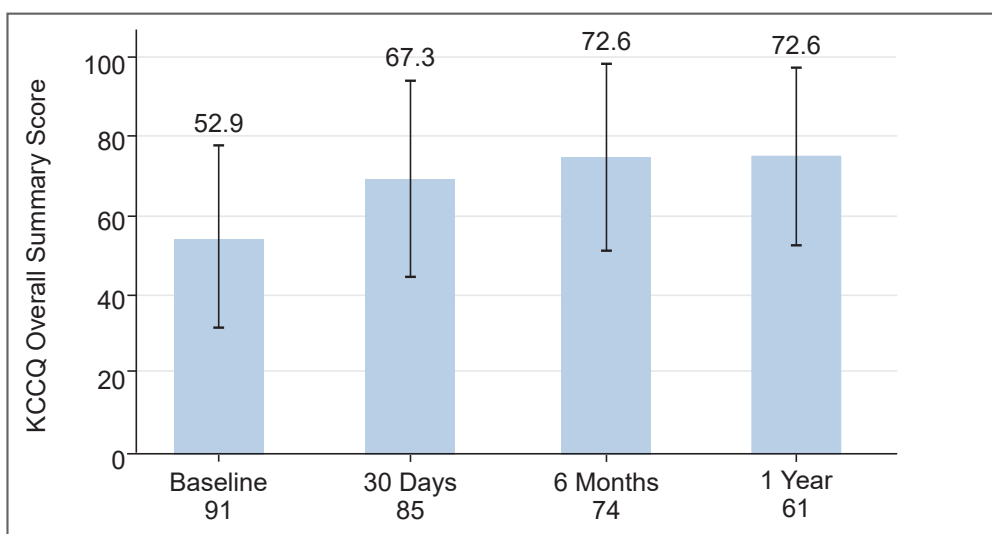

Note: The error bars represent standard deviations.

EQ-5D-5L

The results for the EQ-5D-5L VAS are presented in Figure 24. The mean score was 60.7 at baseline and 72.4 at 1 year post-procedure.

**Figure 24: EQ-5D-5L Visual Analog Score by Visit - MAC Registry
(VI Population)**

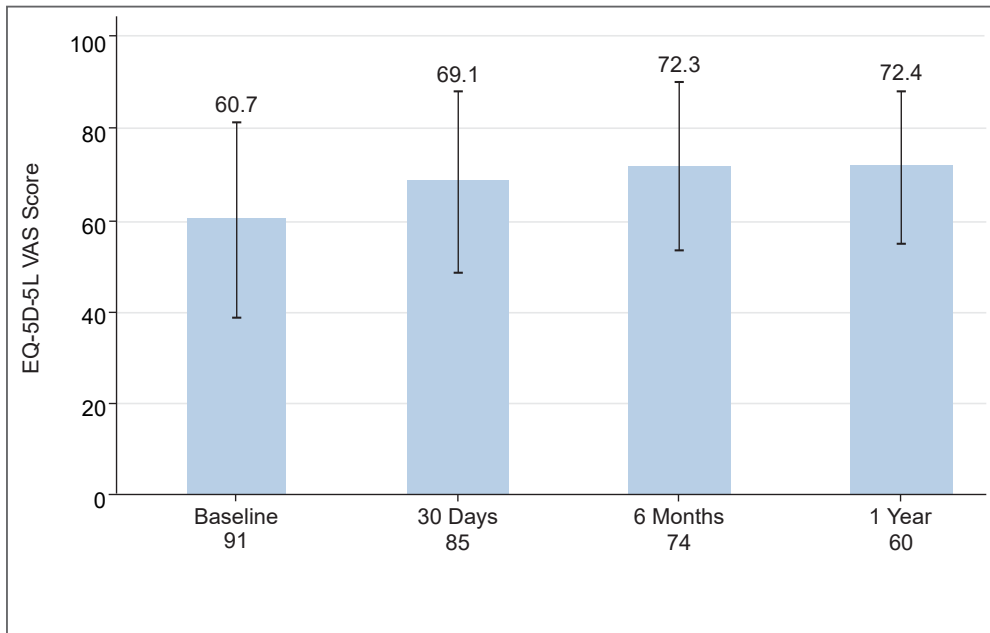

Note: The error bars represent standard deviations.

NYHA Functional Class

The NYHA classifications by visit are presented in Figure 25. At 1 year post-procedure, 87.9% of patients were in NYHA class I/II compared to 26.9% at baseline.

**Figure 25: NYHA Functional Class by Visit - MAC Registry
(VI Population)**

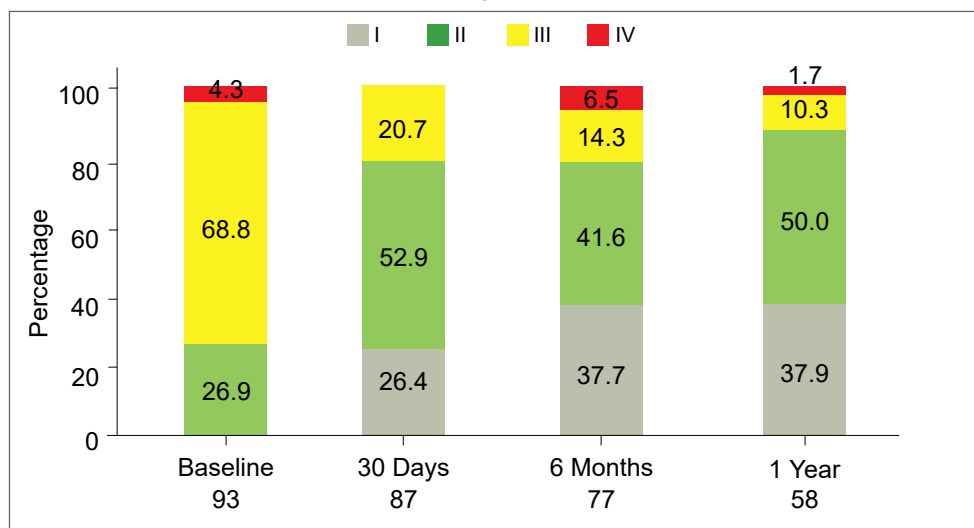

6MWT Distance

The results for the 6MWT distance are presented in Figure 26. The mean walk distance increased from 230.7 meters at baseline to 284.1 meters at 1 year post-procedure.

**Figure 26: 6MWT Distance by Visit - MAC Registry
(VI Population)**

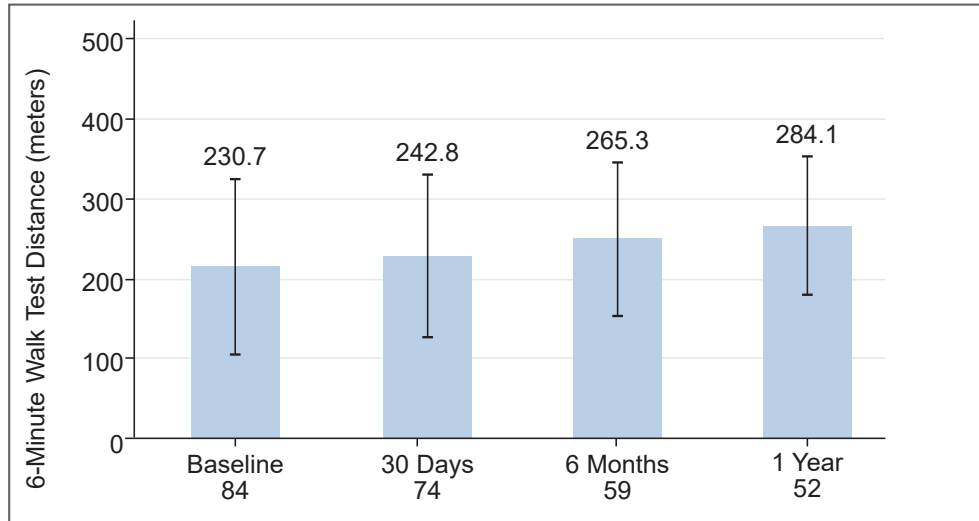

Note: The error bars represent standard deviations.

MR severity

MR severity by visit is shown in Figure 27. MR reduction to $\leq 1+$ was achieved in 98.2% of patients at 1 year.

**Figure 27: MR Severity by Visit - MAC Registry
(VI Population)**

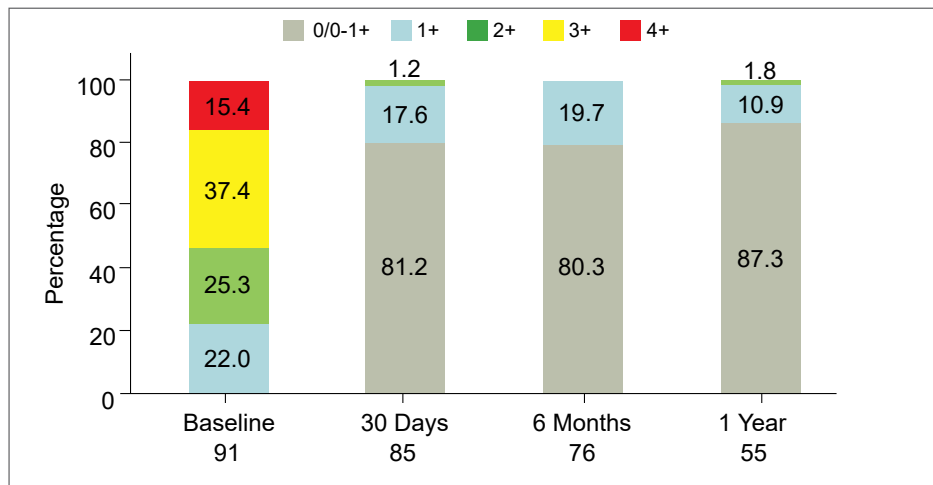

Note: The worst case between transesophageal echocardiogram and transthoracic echocardiogram results was used as the baseline and transthoracic echocardiogram results were used for all other visits.

4. Adverse Events

The Kaplan-Meier estimates of CEC-adjudicated serious adverse events and other adverse events of clinical interest through 1 year are presented in Table 15.

**Table 15: CEC-Adjudicated Adverse Events Through 1 Year - MAC Registry
(AT Population)**

Event	Kaplan Meier Estimate*		
	30 Days	6 Months	1 Year
All-cause death	6.0% (6, 6)	12.4% (12, 12)	21.7% (20, 20)
Cardiovascular	6.0% (6, 6)	8.2% (8, 8)	15.6% (14, 14)
Non-cardiovascular	0.0% (0, 0)	4.6% (4, 4)	7.2% (6, 6)
Heart failure rehospitalization	5.2% (5, 5)	15.5% (17, 14)	19.6% (25, 17)
All stroke	1.0% (1, 1)	1.0% (1, 1)	7.8% (7, 6)
Disabling	0.0% (0, 0)	0.0% (0, 0)	5.5% (5, 4)
Non-disabling	1.0% (1, 1)	1.0% (1, 1)	2.3% (2, 2)
Acute kidney injury Stage 2	3.1% (3, 3)	---	---
Acute kidney injury Stage 3	1.0% (1, 1)	---	---
New-onset atrial fibrillation	12.1% (4, 4)	21.7% (7, 7)	21.7% (7, 7)

Event	Kaplan Meier Estimate*		
	30 Days	6 Months	1 Year
New permanent pacemaker implantation	6.6% (4, 4)	6.6% (4, 4)	11.6% (6, 6)
Life-threatening bleeding	7.0% (8, 7)	10.3% (11, 10)	11.6% (12, 11)
Fatal bleeding	2.0% (2, 2)	3.2% (3, 3)	4.6% (4, 4)
Hemolysis [†]	4.0% (4, 4)	4.0% (4, 4)	4.0% (4, 4)
Hemolytic anemia [‡]	9.2% (9, 9)	9.2% (9, 9)	9.2% (9, 9)
Valve thrombosis	1.0% (1, 1)	4.4% (4, 4)	5.8% (5, 5)
Clinically significant leaflet thrombosis [§]	1.0% (1, 1)	1.0% (1, 1)	2.5% (2, 2)
Dock fracture	0.0% (0, 0)	0.0% (0, 0)	0.0% (0, 0)
Dock migration	0.0% (0, 0)	0.0% (0, 0)	0.0% (0, 0)
Valve embolization	1.0% (1, 1)	1.0% (1, 1)	1.0% (1, 1)
Valve fracture	0.0% (0, 0)	0.0% (0, 0)	0.0% (0, 0)
Valve migration	0.0% (0, 0)	0.0% (0, 0)	0.0% (0, 0)
Clinically significant TMVR-related LVOT obstruction	1.0% (1, 1)	1.0% (1, 1)	5.0% (4, 4)
Mitral valve reintervention	3.1% (3, 3)	8.8% (8, 8)	11.6% (10, 10)
Balloon mitral valvuloplasty	0.0% (0, 0)	0.0% (0, 0)	0.0% (0, 0)
Percutaneous paravalvular leak closure	3.1% (3, 3)	7.7% (7, 7)	9.0% (8, 8)
Surgical mitral valve replacement	0.0% (0, 0)	1.1% (1, 1)	2.6% (2, 2)
Valve in valve	0.0% (0, 0)	0.0% (0, 0)	0.0% (0, 0)
Other	0.0% (0, 0)	0.0% (0, 0)	0.0% (0, 0)
Myocardial infarction	2.1% (2, 2)	3.2% (3, 3)	4.6% (4, 4)
Transient ischemic attack (TIA)	0.0% (0, 0)	1.1% (1, 1)	1.1% (1, 1)
Study device related endocarditis	1.1% (1, 1)	1.1% (1, 1)	1.1% (1, 1)
Major vascular complication	2.0% (2, 2)	2.0% (2, 2)	2.0% (2, 2)
Major access site complication	5.0% (5, 5)	7.3% (7, 7)	7.3% (7, 7)
Atrial septal defect	5.0% (5, 5)	7.3% (7, 7)	7.3% (7, 7)
Major cardiac structure complication	7.0% (7, 7)	9.2% (9, 9)	9.2% (9, 9)

TMVR: transcatheter mitral valve replacement; LVOT: left ventricular outflow obstruction.
*Kaplan-Meier estimate - % (no. events, no. of patients with the event).
†Hemolysis: the presence of a paravalvular leak on echocardiogram plus acute decrease in haptoglobin levels and/or increase in serum lactate dehydrogenase (LDH) levels and/or standard blood examinations supporting hemolysis with associated anemia and diagnosis of hemolysis due to prosthetic valve, not requiring transfusion.
‡Hemolytic anemia: hemolysis requiring transfusion or intervention (or need for intervention) on the mitral valve.
§Inadequate anticoagulation (no anticoagulation, gap in treatment, or subtherapeutic) appeared to be a factor in the occurrence of device thrombosis regardless of the type of anticoagulation prescribed.
||Only interventions after procedure.

5. Subgroup Analyses

The primary endpoint results by gender are presented in Table 16. Kaplan–Meier estimates of all-cause death at 1 year were higher in female patients (38.3%) compared with male patients (6.3%). *Post hoc* analyses on demographics and baseline characteristics revealed no clear predictors for the higher observed mortality rate in female patients than that in male patients. The majority of the deaths were adjudicated by the CEC to be unrelated to the procedure or device.

**Table 16: Primary Endpoint Result by Gender - MAC Registry
(AT Population)**

Event	Summary Statistics*	
	Male (N=51)	Female (N=49)
All-cause death or heart failure rehospitalization at 1 year	26.8% (13)	41.7% (19)
All-cause death	6.3% (3)	38.3% (17)
Heart failure rehospitalization	21.0% (10)	18.1% (7)

*Kaplan-Meier estimate % (no. of patients with the event).

The primary endpoint result by race is shown in Table 17.

**Table 17: Primary Endpoint Result by Race - MAC Registry
(AT Population)**

Race	All-cause Mortality and Heart Failure Rehospitalization*
	(N=100)
White or Caucasian	30/85
Black or African American	0/1
Native Hawaiian or Other Pacific Islander	0/0
Asian	0/2
American Indian or Alaskan Native	0/0
Other	0/2
Unknown	2/10

*no. of patients with events/total no. patients in the subgroup.

6. Other Study Observations

Procedural Information

The procedural data are presented in Table 18.

**Table 18: Procedure Data - MAC Registry
(AT Population)**

Variable	Summary Statistics*
Procedure time (min) [†]	127.1 ± 49.85 (98)
Total fluoroscopy time (min)	57.4 ± 32.14 (100)
Dock deployment time (min) [‡]	70.5 ± 36.74 (97)
Multiple valve implant	3.0% (3/100)
Percutaneous paravalvular leak closure	12.0% (12/100)
Procedure aborted	7.0% (7/100)
Conversion to surgery	1.0% (1/100)

*Continuous measures - mean ± SD (n); categorical measures - % (no./total no.).
[†]Defined as the time from femoral vein access to guide sheath removal.
[‡]Defined as the time from steerable catheter insertion to removal.

Index Hospitalization

The index hospitalization information is presented in Table 19.

**Table 19: Index Hospitalization Information - MAC Registry
(VI Population)**

Variable	Summary Statistics*
Index hospitalization stay (days) [†]	3.0 ± 3.38 (88)
Intensive care stay (days)	0.5 ± 1.30 (88)
In-hospital death	5.4% (5/93)

*Continuous measures - mean ± SD (total no.); categorical measures - % (no./total no.).
[†]Index hospitalization stay excludes in-hospital deaths.

Additional Echocardiographic Data

Additional echocardiographic data through 1 year are presented in Table 20, which show improved hemodynamics.

**Table 20: Additional Echocardiographic Data - MAC Registry
(VI Population)**

Parameter	Summary Statistics*			
	Baseline	30-days	6-months	1-year
LV end diastolic volume index (mL/m ²)	57.6 ± 22.20 (91)	56.6 ± 18.89 (79)	57.1 ± 18.51 (63)	57.8 ± 17.45 (48)
LV end diastolic diameter (cm)	5.0 ± 0.07 (93)	4.9 ± 0.07 (80)	4.9 ± 0.08 (73)	5.0 ± 0.09 (51)
LV ejection fraction (%)	54.7 ± 10.43 (93)	46.5 ± 10.67 (86)	46.2 ± 10.07 (76)	48.9 ± 10.22 (56)
LV end diastolic volume (mL)	111.5 ± 44.47 (91)	110.3 ± 38.92 (79)	111.4 ± 37.11 (63)	116.8 ± 37.49 (48)
LV end systolic volume (mL)	51.8 ± 28.13 (91)	59.7 ± 28.80 (74)	60.5 ± 28.89 (59)	59.7 ± 27.13 (46)

Parameter	Summary Statistics*			
	Baseline	30-days	6-months	1-year
Transmitral antegrade mean gradient (mmHg)	6.0 ± 3.24 (93)	5.6 ± 1.76 (85)	5.4 ± 1.68 (75)	5.6 ± 2.20 (56)
Stroke volume index (mL/m ²)	27.7 ± 8.23 (88)	36.2 ± 14.69 (82)	34.7 ± 10.11 (71)	35.5 ± 12.43 (50)
Cardiac output index (L/min/m ²)	2.0 ± 0.58 (88)	2.7 ± 1.12 (82)	2.5 ± 0.71 (71)	2.5 ± 0.74 (50)
LV: left ventricular. *Continuous measures - mean ± SD (n).				

Symbol Legend

English		English		English	
	Reorder Number		Sterile		Importer
	Model Number		Sterilized using ethylene oxide		Balloon diameter
	Usable length		Sterilized using liquid chemical		Balloon working length
	Do not re-use		Do not re-sterilize		For use with size 29 mm Edwards transcatheter heart valve
	Lot Number		Single sterile barrier system		MR Conditional
	Caution		Single sterile barrier system with protective packaging inside		Contents
	Consult instructions for use		Quantity		Non-pyrogenic
	Consult instructions for use on the website		Use-by date		Medical device
	Do not use if package is damaged and consult instructions for use		Serial Number		Contains biological material of animal origin
	Exterior Diameter		Manufacturer		Caution: Federal (USA) law restricts this device to sale by or on the order of a physician.
	Inner diameter		Date of manufacture		Time & Temperature Sensitive
	Store in a cool, dry place		Guidewire compatibility		Contains hazardous substances
	Keep dry		Nominal Pressure		Size
	Keep away from sunlight		Rated burst pressure		Work Order
	Unique Device Identifier		Recommended guidewire length		
	Temperature limit		Minimum sheath size		
			Catheter shaft size		

Note: Not all symbols may be included in the labeling of this product.



Edwards

2025-12
60050527001 A
© Copyright 2025, Edwards Lifesciences LLC
All rights reserved.



Edwards Lifesciences LLC
One Edwards Way
Irvine, CA 92614 USA

Telephone +1.949.250.2500
+1.800.424.3278
FAX +1.949.250.2525

Web IFU