



Edwards

Edwards PASCAL Precision Transcatheter Valve Repair System

Instructions for Use

Rx only

The Edwards PASCAL Precision transcatheter valve repair system includes (herein referred to as the PASCAL Precision system):

Model	Device
20000IS	PASCAL Precision system - implant system
20000ISM	PASCAL Precision system - PASCAL Ace implant system
20000GS	PASCAL Precision system - guide sheath

The PASCAL Precision system is compatible with the following single-use accessories:

Model	Device
10000T	PASCAL system - table
20000ST	PASCAL system - stabilizer rail system

The PASCAL Precision system is compatible with the following reusable accessories:

Model	Device
10000UP	Edwards reusable platform
10000PT	Edwards reusable plate
10000CR	Edwards reusable cradle

• Implant System

The implant system consists of the steerable catheter (outermost layer), the implant catheter (innermost layer), and the implant (hereinafter refers to implants from model 20000IS and model 20000ISM). The implant system percutaneously delivers the implant to the native valve via a femoral vein access.

• PASCAL Implant (Figures 1-3)

The implant is deployed and secured to the leaflets of the native valve, acting as a filler in the regurgitant orifice. The primary components of the implant are the spacer, paddles, and clasps constructed from nitinol and covered in polyethylene terephthalate. The 20000IS implant also comprises a titanium nut and bolt, PEEK bushing, and a silicone seal. The 20000ISM implant also comprises a titanium nut, bolt, distal and proximal plate, and a silicone seal and is a smaller size implant.

The implant has four main paddle positions: elongated, closed, leaflet-capture-ready, and leaflet-captured.

Edwards, Edwards Lifesciences, the stylized E logo, CLASP, Edwards PASCAL, Edwards PASCAL Precision, PASCAL, PASCAL Ace, and PASCAL Precision are trademarks of Edwards Lifesciences Corporation. All other trademarks are the property of their respective owners.

- **Implant Catheter (Figure 4)**

The implant is provided attached to the implant catheter by sutures and a threaded shaft. The implant catheter controls the deployment of the implant. The four primary controls are the clasp sliders, the paddle knob, the implant release knob, and the suture locks. The clasp sliders control the clasps (retracting the clasp sliders raises the clasps and advancing the clasp sliders lowers the clasps). The paddle knob controls the paddles (rotating the paddle knob clockwise closes the paddles and rotating the paddle knob counterclockwise opens the paddles). The implant release knob controls the release of the implant from the implant catheter. The suture locks control release of the sutures from the clasps. The implant catheter is provided assembled within the steerable catheter.

- **Steerable Catheter (Figure 4)**

The steerable catheter has a rotational control knob (flex knob) that actuates the flexion mechanism to navigate and position the implant to the target location. A radiopaque marker band located on the distal portion of the catheter indicates the end of the flex section.

- **Guide Sheath (Figure 5)**

The guide sheath set includes a steerable guide sheath and introducer. The guide sheath provides atrial access. It has a hydrophilic coating and a rotational control knob (flex knob) which actuates the flexion mechanism to position the guide sheath at the target location.

The introducer is compatible with a 0.035 in (0.89 mm) guidewire.

- **Stabilizer Rail System (Figure 6)**

The stabilizer rail system is indicated to aid with positioning and stabilization of the PASCAL Precision system during implantation procedures. The stabilizer rail system can be attached to the guide sheath and implant system as needed any time during the procedure. The use of the stabilizer rail system is recommended.

- **Table (Figure 7)**

The table is used outside of the sterile field to provide a stable platform for the implant system, guide sheath, and stabilizer rail system. The table is height-adjustable. The use of the table is recommended.

- **Reusable Accessories**

For reusable accessories, refer to the Edwards Reusable Accessories: Reusable Platform (Model 10000UP), Reusable Plate (Model 10000PT), and Reusable Cradle (Model 10000CR) Instructions for Use (herein referred to as the Edwards Reusable Accessories IFU).

- **Loader (Figure 8)**

The loader is used to introduce the implant system through the guide sheath seals. The loader is included in the implant system and guide sheath packaging for user convenience.

1.0 Indications

The PASCAL Precision transcatheter valve repair system (the PASCAL Precision system) is indicated for the percutaneous reduction of significant, symptomatic mitral regurgitation ($MR \geq 3+$) due to primary abnormality of the mitral apparatus (degenerative MR) in patients who have been determined to be at prohibitive risk for mitral valve surgery by a heart team, which includes a cardiac surgeon experienced in mitral valve surgery and a cardiologist experienced in mitral valve disease, and in whom existing comorbidities would not preclude the expected benefit from reduction of the MR.

2.0 Contraindications

The PASCAL Precision system is contraindicated in patients with the following conditions:

- Patients who cannot tolerate procedural anticoagulation or post procedural anti-platelet regimen
- Untreatable hypersensitivity or contraindication to nitinol alloys (nickel and titanium) or contrast media
- Active endocarditis of the mitral valve
- Rheumatic etiology for mitral regurgitation
- Evidence of intracardiac, inferior vena cava (IVC) or femoral venous thrombus

3.0 Warnings

3.1 Device Handling

3.1.1 PASCAL Precision System, Table, and Stabilizer Rail System

- The devices are designed, intended, and distributed for single use only. There are no data to support the sterility, non-pyrogenicity, and functionality of the devices after reprocessing.

-
- Devices should be handled using standard sterile technique to prevent infection.
 - Do not expose any of the devices to any solutions, chemicals, etc., except for the sterile physiological and/or heparinized saline solution. Irreparable damage to the device, which may not be apparent under visual inspection, may result.
 - Do not use any of the devices in the presence of combustible or flammable gases, anesthetics, or cleaners/disinfectants.
 - Do not use the devices if the expiration date has elapsed.
 - Do not use if the packaging seal is broken or if the packaging is damaged for sterile devices.
 - Do not use if any of the devices were dropped, damaged, or mishandled in any way.
 - Standard flushing and de-airing technique should be used during preparation and throughout procedure to prevent air embolism.

3.1.2 Edwards Reusable Platform, Reusable Plate, and Reusable Cradle

- The devices are designed, intended, and distributed for multiple uses. For reusable accessories, refer to the Edwards Reusable Accessories IFU.

3.2 Clinical Warnings

- As with any implanted medical device, there is a potential for an adverse immunological response.
- Serious adverse events, sometimes leading to surgical intervention and/or death, may be associated with the use of this system ("Potential Adverse Events"). A full explanation of the benefits and risks should be given to each prospective patient before use.
- Careful and continuous medical follow-up is advised so that implant-related complications can be diagnosed and properly managed.
- Anticoagulation therapy must be determined by the physician per institutional guidelines.

4.0 Precautions

4.1 Precautions Prior to Use

- Patient selection should be performed by a heart team to assess patient risk and anatomical suitability.

4.2 Precautions After Use

- Short-term anticoagulation therapy may be necessary after valve repair with the PASCAL Precision system. Prescribe anticoagulation and other medical therapy per institutional guidelines.

5.0 Special Patient Populations

5.1 Pregnancy

- The PASCAL Precision system has not been tested in pregnant women. Effects on the developing fetus have not been studied. The risks and reproductive effects are unknown at this time.

5.2 Gender

- No safety or effectiveness related gender differences were observed in clinical studies.

5.3 Ethnicity

- Insufficient subject numbers prevent ethnicity-related analyses on the clinical safety and effectiveness.

5.4 Pediatrics

- Safety and effectiveness of the PASCAL Precision system has not been established in pediatric patients.

6.0 Potential Adverse Events

Below is a list of the potential adverse effects (e.g., complications) associated with the use of the PASCAL Precision system:

- Death
- Abnormal laboratory values
- Allergic reaction to anesthetic, contrast, heparin, Nitinol
- Anemia or decreased hemoglobin (may require transfusion)
- Aneurysm or pseudoaneurysm
- Angina or chest pain
- Anaphylactic shock
- Arrhythmias – atrial (i.e. atrial fibrillation, Supraventricular tachycardia)
- Arrhythmias – ventricular (i.e. ventricular tachycardia, ventricular fibrillation)

-
- Arterio-venous fistula
 - Atrial septal injury requiring intervention
 - Bleeding
 - Cardiac arrest
 - Cardiac failure
 - Cardiac injury, including perforation
 - Cardiac tamponade/pericardial effusion
 - Cardiogenic shock
 - Chordal entanglement or rupture that may require intervention
 - Coagulopathy, coagulation disorder, bleeding diathesis
 - Conduction system injury which may require permanent pacemaker
 - Deep vein thrombosis (DVT)
 - Deterioration of native valve (e.g. leaflet tearing, retraction, thickening)
 - Dislodgement of previously deployed implant
 - Dyspnea
 - Edema
 - Electrolyte imbalance
 - Emboli/embolization including air, particulate, calcific material, or thrombus
 - Endocarditis
 - Esophageal irritation
 - Esophageal perforation or stricture
 - Exercise intolerance or weakness
 - Failure to retrieve any PASCAL Precision system components
 - Fever
 - Gastrointestinal bleeding or infarct
 - Heart failure
 - Hematoma
 - Hemodynamic compromise
 - Hemolysis
 - Hemorrhage requiring transfusion or intervention
 - Hypertension
 - Hypotension
 - Implant deterioration (wear, tear, fracture, or other)
 - Implant embolization
 - Implant malposition or failure to deliver to intended site
 - Implant migration
 - Implant thrombosis
 - Infection
 - Inflammation
 - LVOT obstruction
 - Mesenteric ischemia
 - Multi-system organ failure
 - Myocardial infarction
 - Native valve injury
 - Native valve stenosis
 - Nausea and/or vomiting
 - Need for open surgery (conversion, emergent or nonemergent reoperation, explant)
 - Nerve injury
 - Neurological symptoms, including dyskinesia, without diagnosis of TIA or stroke
 - Non-neurological thromboembolic events
 - Pain
 - Papillary muscle damage
 - Paralysis

-
- PASCAL Precision system component(s) embolization
 - Peripheral ischemia
 - Permanent disability
 - Pleural effusion
 - Pulmonary edema
 - Pulmonary embolism
 - Reaction to anti-platelet or anticoagulation agents
 - Renal failure
 - Renal insufficiency
 - Respiratory compromise, respiratory failure, atelectasis, pneumonia – may require prolonged ventilation
 - Retroperitoneal bleed
 - Septal damage or perforation
 - Septicemia, sepsis
 - Skin burn, injury, or tissue changes due to exposure to ionizing radiation
 - Single leaflet device attachment (SLDA)
 - Stroke
 - Syncope
 - Transient ischemic attack (TIA)
 - Urinary tract infection and/or bleeding
 - Valvular regurgitation
 - Vascular injury or trauma, including dissection or occlusion
 - Vessel spasm
 - Ventricular wall damage or perforation
 - Worsening native valve regurgitation / valvular insufficiency
 - Worsening of heart failure
 - Wound dehiscence, delayed or incomplete healing

7.0 How Supplied

7.1 Packaging

The implant system, guide sheath, and stabilizer rail system are individually packaged and ethylene oxide sterilized. The table is packaged and provided non-sterile. The Edwards reusable platform, reusable plate and reusable cradle are individually packaged and provided non-sterile.

7.2 Storage

The PASCAL Precision system should be stored in a cool, dry place.

8.0 Directions for Use

8.1 Physician Training

The implanting physician shall be experienced in transcatheter techniques and trained on the PASCAL Precision system and implant procedure.

8.2 Equipment and Materials

- Standard cardiac catheterization lab equipment
- Fluoroscopy system
- Transesophageal echocardiography (TEE) capabilities (2D and 3D)
- Pigtail catheter for contrast injection (with compatible sheath)
- Venous puncture kit
- Transseptal needle, sheath, and guidewire
- Exchange length 0.035 inch (0.89 mm) guidewire
- Basins
- 50-60 cc syringes with Luer fitting
- Heparinized saline
- Hemostat

- Surgical towels (e.g. size 43 x 69 cm)
- Optional: step-up dilators
- Optional: continuous physiological saline drip (rolling IV pole, IV tubing with thumbwheel occluders, 1-liter bags of heparinized sterile saline solution)
- Optional: pressure monitoring device

8.3 Device Preparation

8.3.1 Table

Step	Procedure
1	Remove the table from packaging and inspect for damage. If using the Edwards reusable platform and reusable cradle in lieu of the table, refer to the Edwards Reusable Accessories IFU.
2	Assemble the table as seen in Figure 7.

8.3.2 Stabilizer Rail System

Step	Procedure
1	Remove stabilizer rail system components from packaging and inspect for damage.

8.3.3 Guide Sheath

Step	Procedure
1	Remove the guide sheath, loader, and introducer from packaging and inspect for gross damage.
2	Flush and de-air with heparinized saline.
3	Wipe guide sheath with heparinized saline prior to use.

8.3.4 Implant System – System Check, Clasp Check, and Resetting

Step	Procedure
1	Remove implant system and loader from packaging and inspect for gross damage. CAUTION: If vented cap is not present on the implant catheter flush port, use of the device may result in infection.
2	Fully elongate implant. Fully retract and advance clasp sliders to confirm proper clasp motion.
3	If clasps do not move properly, follow steps below to reset. If clasps do move properly, continue to next section “Implant System – Flushing and Preparation”.
4	Ensure implant is fully closed. Loosen and remove suture locks from suture lock base. Note: Ensure free end of suture is not pulled into handle while loosening suture locks.
5	Fully retract clasp sliders and place clasp setting tool flush with suture locks, suture lock bases, and implant release knob.
6	Pull free end of suture on one suture lock base to remove suture slack. Release tension on free end of suture, replace and tighten the suture lock. Repeat for second suture lock.
7	Remove clasp setting tool. Fully elongate implant. Fully advance and retract sliders to confirm proper clasp motion.

8.3.5 Implant System – Flushing and Preparation

Step	Procedure
1	Close implant.
2	Ensure clasp sliders are fully retracted and implant is fully closed.
3	Remove vented cap from implant catheter flush port. Raise distal end of the implant catheter and flush with heparinized saline.

Step	Procedure
4	Attach flush port cap to implant catheter flush port.
5	Attach implant release cover to implant catheter handle.
6	Fully retract implant catheter. Advance the clasp sliders and set implant in elongated position.
7	Remove loader cap and guide the loader cap onto the implant system.
8	Insert the implant through the proximal end of the loader until it exits the distal end. Connect the loader and loader cap.
9	Advance implant catheter fully so implant exits loader.
10	Flush heparinized saline through the steerable catheter.
11	Advance the loader until the distal end of the implant is fully in the loader.

8.4 Implant Procedure

Delivery of the implant should be performed under general anesthesia with hemodynamic monitoring in an operating room, hybrid operating room, or cath lab with fluoroscopic and echocardiographic imaging capabilities.

CAUTION: During the procedure, heparin should be administered so that the ACT is maintained at ≥ 250 sec.

CAUTION: Excessive contrast media may lead to renal failure. Measure the patient's creatinine level prior to the procedure. Contrast media usage should be monitored.

8.4.1 Patient Preparation

Step	Procedure
1	<p>Prior to sterile draping the patient, assemble and position the table between the legs of the patient, adjusting height of the table as needed. Use towels as support between table and patient's legs.</p> <p>CAUTION: The table is provided non-sterile; introduction of the table into the sterile field may result in infection.</p> <p>OR</p> <p>Prior to sterile draping the patient, assemble and position the reusable accessories around the legs of patient, adjusting the height and angle of the platform as needed. Place the cradle on the platform in line with the intended femoral vein access site. Refer to the Edwards Reusable Accessories IFU.</p> <p>CAUTION: The reusable accessories are non-sterile; introduction of the reusable accessories into the sterile field may result in infection.</p>
2	After sterile draping is complete, assemble and attach stabilizer rail system as needed any time during procedure.

8.4.2 Femoral Vein Access and Sheath Introduction

Step	Procedure
1	Access the common femoral vein using conventional percutaneous puncture methods.
2	<p>Access the left atrium via transvenous, transeptal techniques using conventional percutaneous methods and place guidewire in left atrium. Dilate the vessel, as needed.</p> <p>CAUTION: Inappropriate puncture may result in cardiac structure damage requiring surgical repair or other intervention.</p>
3	<p>Insert guide sheath with introducer over guidewire until guide sheath tip is securely across the septum, using flex mechanism as needed.</p> <p>CAUTION: Excessive manipulation may result in dislodgement or disturbance of a previously implanted device, cardiac structure damage requiring surgical repair or other intervention.</p>
4	<p>Remove the introducer and guidewire. Do not aspirate and flush the guide sheath until the implant system is inserted.</p> <p>CAUTION: Aspiration or connection of a continuous physiological saline flush to the guide sheath prior to implant system insertion may result in air embolism.</p>

8.4.3 Implant Delivery

Step	Procedure
1	Insert the implant system with the loader into the guide sheath.
2	Advance implant system until the implant exits the loader. Retract and peel away the loader.
3	Aspirate and flush guide sheath with heparinized saline. Utilizing the specified syringe, aspirate a minimum of 45 cc. CAUTION: Failure to fully aspirate guide sheath or aspiration without the presence of the flush port cap on the implant catheter flush port may result in air embolism.
4	If desired, connect the continuous physiological saline drip to the implant catheter. CAUTION: Connection of the continuous physiological saline drip to the implant system prior to aspiration may result in air embolism.
5	Advance implant system until the implant exits the distal end of the guide sheath.
6	Set the implant in closed position. Retract the clasp sliders.
7	Adjust guide sheath as needed.
8	At the discretion of the treating physician, if pressure monitoring is used to continuously assess atrial pressure during procedure, please follow the pressure monitor manufacturer's instruction of use. Connect a fluid filled pressure monitoring device to the steerable catheter. Aspirate and then calibrate at the patient's heart level before obtaining measurement. Note: Pressure monitoring should be used in conjunction with echo. Pressure should be reconciled against echo and Doppler readings. When assessing atrial pressure, ensure that the distal tip of the implant catheter is fully exposed from the steerable catheter.
9	Advance implant system as needed. Manipulate steerable catheter and guide sheath (flex-unflex, torque in opposing directions, advance-retract) as needed until implant is centered in the target coaptation zone with the appropriate trajectory. CAUTION: Excessive manipulation may result in dislodgement or disturbance of a previously implanted device, cardiac structure damage requiring surgical repair, or other intervention. Note: The radiopaque marker band on the steerable catheter indicates the end of the flex section and can be visualized on fluoroscopy.
10	Rotate the paddle knob to get the implant into leaflet-capture-ready position.
11	Torque the implant catheter, as needed, to orient the paddles.
12	Move one clasp slider to identify which clasp it controls via imaging. Once identified, ensure clasp sliders are fully retracted.
13	Advance the implant through the valve until paddles are below the free edge of the leaflets.
14	Verify location and orientation of the implant and adjust position slightly as needed. CAUTION: Excessive manipulation of the implant below the leaflets may cause the implant to be entangled in the chords; chordal entanglement may result in cardiac injury, worsening regurgitation, difficulty or inability to remove the implant requiring additional intervention.
15	Under imaging guidance, retract the implant until leaflets are positioned between paddles and clasps.
16	Advance clasp slider(s) so the leaflet(s) are secured between the clasps and paddles. This can be performed for both leaflets simultaneously (clasp lock engaged to move both clasps) or each leaflet individually (clasp lock disengaged to move individual clasp).
17	Verify leaflet insertion with imaging. If leaflet(s) are not secured between clasps and paddles, retract the clasp slider(s) to release the leaflet(s) and reattempt.
18	Once leaflets are secured between the clasps and paddles, close the implant.

Step	Procedure
19	Advance implant catheter slightly to release tension on leaflets.
20	<p>Assess regurgitation and reposition as needed. Once the implant position is confirmed, ensure implant is closed.</p> <p>If repositioning within the ventricle is needed, retract the clasp sliders and set the implant in leaflet-capture-ready position. Adjust clasps and implant orientation as needed.</p> <p>If repositioning within the atrium is needed, retract the clasp sliders and elongate the implant slowly under fluoroscopic guidance while ensuring that the actuation wire does not bend, and retract the implant back into the atrium.</p> <p>CAUTION: Failure to elongate the implant when retracting into the atrium during repositioning may result in leaflet damage or chordal entanglement.</p> <p>CAUTION: Failure to release leaflets from clasps and paddles prior to repositioning may result in leaflet damage.</p>

8.4.4 Implant Retrieval (if needed)

Prior to implant release, if needed, it is possible to retrieve the implant system back into the guide sheath for removal. Follow the steps below to retrieve the implant.

CAUTION: Excessive manipulation may result in dislodgement or disturbance of a previously implanted device, cardiac structure damage requiring surgical repair, or other intervention.

Step	Procedure
1	Retract the clasp sliders.
2	Elongate the implant slowly under fluoroscopic guidance while ensuring that the actuation wire does not bend. Then retract implant into the atrium. Set the implant in closed position.
3	Unflex the steerable catheter and retract the implant system until the implant is adjacent to the tip of the guide sheath.
4	Advance the clasp sliders.
5	Set the implant in elongated position.
6	Retract the clasp sliders to open the clasps to approximately 45° on each side.
7	Retract entire implant system through the guide sheath.

8.4.5 Implant Release

To release the implant follow the steps below:

CAUTION: Failure to follow prescribed release steps may result in difficulty or inability to release implant, requiring additional intervention.

CAUTION: Releasing the implant prior to confirmation that leaflets are securely captured between paddles and clasps may result in implant movement or dislodgement leading to a single leaflet device attachment (SLDA) or other potential adverse events requiring additional intervention.

CAUTION: Re-use of the devices (including implant system and guide sheath) after retrieval may cause embolism of foreign material or infection. Device may malfunction if re-use is attempted.

Note: If an additional implant [PASCAL or PASCAL Ace] is placed at the decision of the treating physician, caution should be taken to avoid dislodgement of the previously placed implant. Crossing the valve in a low profile implant configuration can minimize interaction with the previously placed implant.

CAUTION: Excessive manipulation may result in dislodgement or disturbance of a previously implanted device, cardiac structure damage requiring surgical repair, or other intervention.

Step	Procedure
1	Ensure that the distal tip of the implant catheter is fully exposed from the steerable catheter.
2	Unscrew and remove implant release cover from implant catheter handle.
3	Unthread and remove one suture lock from the suture lock base.

Step	Procedure
4	Pull suture lock away from handle to fully remove suture.
5	Repeat steps for other suture lock.
6	Rotate counterclockwise and retract the implant release knob until the implant is released, as confirmed via imaging.
7	Replace suture locks, as needed.

8.4.6 Device Removal and Closure

Step	Procedure
1	Retract implant catheter completely into steerable catheter. Gradually unflex and remove implant system. Gradually unflex and remove guide sheath. CAUTION: Failure to unflex devices prior to removal may result in vessel damage.
2	Perform standard percutaneous closure of access site.

9.0 Magnetic Resonance (MR) Safety

Non-clinical testing has demonstrated that the PASCAL and PASCAL Ace implants are MR Conditional. A patient with this device can be safely scanned in an MR system meeting the following conditions:

- Static magnetic fields of 1.5 T and 3.0 T
- Maximum spatial field gradient of 3,000 gauss/cm (30 T/m)
- Maximum MR system-reported, whole body averaged specific absorption rate (SAR) of 4 W/kg (First Level Controlled Operating Mode).

Under the scan conditions defined above, the implant is expected to produce a maximum temperature rise of less than 4 °C after 15 minutes of continuous scanning.

In non-clinical testing, the image artifact caused by the device in a worst case multiple implant configuration extends up to 15 mm from the implant when imaged in the worst case gradient echo pulse sequence in a 3.0 T MRI system.

10.0 Recovered Implant and Device Disposal

Edwards Lifesciences is interested in obtaining recovered clinical specimens of the implant for analysis. A written report summarizing our findings will be provided upon completion of our evaluation. Please contact Edwards for return of the recovered implant.

If you do decide to return any of the devices, please follow the following instructions:

- **Unopened Package with Sterile Barrier Intact:**

If the pouches have not been opened, return the device in its original packaging.

- **Package Opened but Not Implanted:**

If a pouch is opened, the device is no longer sterile. Please return the device in its original packaging.

- **Explanted Implant:**

The explanted implant should be placed into a suitable histological fixative such as 10% formalin or 2% glutaraldehyde and returned to Edwards.

10.1 Disposal

Used single use devices may be handled and disposed of in the same manner as hospital waste and bio-hazardous materials in accordance with local regulations as there are no special risks related to the disposal of these devices.

For disposal of the reusable accessories, refer to the Edwards Reusable Accessories IFU.

11.0 Patient Information

A patient implant card is provided with each implant system. After implantation, please complete all requested information and provide the implant card to the patient. This implant card allows patients to inform healthcare providers what type of implant they have when they seek care.

12.0 Clinical Data

The PASCAL Precision system and the PASCAL system (herein referred to as PASCAL system) was studied in a clinical trial entitled "CLASP IID trial."

A. Study Design

The main cohort of the CLASP IID trial was a prospective, multicenter, randomized, parallel-group study. Eligible patients were randomized (2:1) into two groups: PASCAL system and MitraClip system. The CLASP IID trial also had a single-arm side registry that enrolled eligible patients deemed inappropriate for randomization due to complex mitral valve anatomy deemed suitable for treatment with the PASCAL system, but not for the MitraClip System.

The CLASP IID trial employed a Central Screening Committee (CSC) that ensured patient appropriateness for enrollment, an independent Data Safety Monitoring Board (DSMB) that was instructed to notify the applicant of any safety or compliance issues, a Clinical Events Committee (CEC) that was responsible for adjudicating endpoint related events reported during the trial, and an echocardiographic core laboratory for independently analyzing all echocardiograms.

1. Clinical Inclusion and Exclusion Criteria

Enrollment in the CLASP IID trial was limited to patients who met the following inclusion criteria:

- Eighteen (18) years of age or older.
- Patient is able and willing to give informed consent and follow protocol procedures and comply with follow-up visit requirements.
- Patient is determined to be at prohibitive risk for mitral valve surgery by the heart team.
- Patient is determined to be a candidate for transcatheter mitral valve repair by the heart team for both PASCAL system and MitraClip (for randomized cohort only).
- Patient must be deemed a candidate for transseptal catheterization by the site interventional operator.
- Mitral regurgitation (3+ to 4+) as measured by the Echocardiographic Core Laboratory via transthoracic echocardiogram (TTE) or transesophageal echocardiogram (TEE).
- Suitable valve and regurgitant jet morphology.
- Left ventricular ejection fraction (LVEF) > 20%.
- LVEDD < 80 mm by TTE.

Patients were not permitted to be enrolled in the CLASP IID trial if they met any of the following exclusion criteria:

- Patient in whom a TEE is contraindicated or screening TEE is unsuccessful.
- Mitral valve anatomy which may preclude proper PASCAL system or MitraClip (for randomized cohort only) access, use and/or deployment or sufficient reduction in MR.
- Echocardiographic evidence of intracardiac mass, thrombus, or vegetation. Chronic scarred thrombi may be considered for inclusion by the core laboratory.
- Echocardiographic evidence of severe right ventricular dysfunction per core laboratory assessment.
- Patient with refractory heart failure requiring advanced intervention (i.e., left ventricular assist device, transplantation; American College of Cardiology/American Heart Association Stage D heart failure).
- Clinically significant, untreated coronary artery disease.
- Recent stroke.
- Other severe valve disorders requiring intervention or left ventricular outflow obstruction.
- Infiltrative cardiomyopathies (e.g., amyloidosis, hemochromatosis, sarcoidosis), hypertrophic cardiomyopathy, restrictive cardiomyopathy, constrictive pericarditis, or any other structural heart disease causing heart failure other than dilated cardiomyopathy of either ischemic or non-ischemic etiology.
- Bradycardia with heart rate < 45 bpm (unless treated with a permanent pacemaker) or uncontrolled tachyarrhythmias.
- Any recent percutaneous coronary, carotid, endovascular intervention, carotid surgery, or cardiac surgery.
- Recent implant or revision of any rhythm management device (i.e., pacemaker, implantable cardioverter defibrillator [ICD], cardiac resynchronization therapy [CRT] with or without cardioverter-defibrillator).
- Tricuspid valve disease requiring surgery or severe tricuspid regurgitation.
- Any planned interventional cardiac procedure.
- Need for emergent or urgent surgery for any reason or any planned cardiac surgery within the next 12 months.
- Any prior mitral valve surgery or transcatheter mitral valve procedure (excluding chordal replacement or surgical annuloplasty repair).
- Active systemic infection, including active endocarditis.
- Active rheumatic heart disease or rheumatic etiology for MR.

- Severe aortic stenosis or regurgitation.
- Absence of CRT with a Class I indication criteria for biventricular pacing.
- Resting systolic blood pressure < 90 or > 160 mmHg after repeated measurements.
- Estimated pulmonary artery systolic pressure (PASP) > 70 mmHg assessed by site based on echocardiography or right heart catheterization, unless active vasodilator therapy in the catheterization laboratory is able to reduce the pulmonary vascular resistance (PVR) to < 3 Wood units or between 3 and 4.5 Wood units with V wave less than twice the mean of the pulmonary capillary wedge pressure.
- Known history of untreated, severe carotid stenosis.
- History of deep vein thrombosis (DVT) or pulmonary embolism (PE).
- Presence of an occluded or thrombosed inferior vena cava (IVC) filter that would interfere with the delivery catheter, or presence of an ipsilateral deep vein thrombosis.
- Severe chronic obstructive pulmonary disease (COPD).
- Severe renal insufficiency with eGFR ≤ 25 ml/min or requiring chronic renal replacement therapy.
- Untreatable hypersensitivity or contraindication to any of the following: aspirin or clopidogrel or ticlopidine; heparin or bivalirudin, or warfarin; nitinol alloys (nickel and titanium); or contrast media.
- Pregnant or planning pregnancy within next 12 months.

Note: Female patients of childbearing potential need to have a negative pregnancy test performed within 14 days prior to intervention and be adherent to an accepted method of contraception.

- Concurrent medical condition with a life expectancy of less than 12 months in the judgment of the Investigator.
- Patient is currently participating in another investigational biologic, drug or device clinical study where the primary study endpoint was not reached at time of enrollment.
- Other medical, social, or psychological conditions that preclude appropriate consent and follow-up, including patients under guardianship.

2. Follow-up Schedule

The follow-up time points included day of implantation, discharge, 30 days, 6 months, 1 year, and annually thereafter to 5 years post procedure. Preoperative and post-operative assessments included physical assessments and medical history, laboratory measurements, imaging tests, and health surveys. Adverse events and complications were recorded at all visits.

3. Clinical Endpoints

The primary safety endpoint was a composite of Major Adverse Events (MAEs) at 30 days, which included: cardiovascular mortality, stroke, myocardial infarction, new need for renal replacement therapy, severe bleeding (defined as major bleeding or above), and non-elective mitral valve re-intervention (either percutaneous or surgical). The hypothesis for the primary safety endpoint of the randomized cohort was as follows:

$$H_0: P_{PASCAL}(T) - P_{MitraClip}(T) \geq 15\%$$

$$H_A: P_{PASCAL}(T) - P_{MitraClip}(T) < 15\%$$

where P_{PASCAL} and $P_{MitraClip}$ represent the proportions of patients with MAEs at 30 days in the PASCAL system and MitraClip arms, respectively, and 15% is the non-inferiority margin

The primary effectiveness endpoint was the proportion of patients with MR ≤ 2+ at 6 months as assessed by TTE by the Echocardiographic Core Laboratory. The hypothesis for the primary effectiveness endpoint of the randomized cohort was as follows:

$$H_0: P_{PASCAL}(T) - P_{MitraClip}(T) \leq -18\%$$

$$H_A: P_{PASCAL}(T) - P_{MitraClip}(T) > -18\%$$

where P_{PASCAL} and $P_{MitraClip}$ represent the proportions of patients with MR ≤ 2+ at 6 months in the PASCAL system and MitraClip arms, respectively, and -18% is the non-inferiority margin.

Both the primary safety and the primary effectiveness hypotheses of the randomized cohort were to be tested at a one-sided significance level of 0.05. The registry cohort was to be analyzed descriptively.

Among the secondary endpoints, those to be evaluated at the 6-month or earlier follow-up time points included the following:

- Major adverse event rate at 6 months
- All-cause mortality at 30 days and 6 months
- Heart failure hospitalization at 30 days and 6 months
- New onset of permanent atrial fibrillation at 30 days

- Non-elective mitral valve re-intervention (either percutaneous or surgical) at 6 months
- Residual atrial septal defect (ASD) by Doppler at 30 days and 6 months
- Transfusion ≥ 2 units of whole blood or packed red blood cells through discharge
- GI complication requiring surgery at 30 days
- 6 Minute Walk Test (6MWT) at 30 days and 6 months
- Quality of life (QoL): Kansas City Cardiomyopathy Questionnaire (KCCQ), SF-36, and EQ-5D-5L at 30 days and 6 months
- Total procedure time (pre-procedure prep time, procedure time, post-procedure time) through discharge
- Total length of stay at discharge

The planned sample size was 300 patients for the randomized cohort and 150 patients for the registry cohort. The randomized cohort employed a Bayesian adaptive design that would allow for three interim analyses by an unblinded independent statistician when 180, 210, and 240 patients, respectively, would have reached the 6-month follow-up. If the predictive probability of success for both the primary safety and effectiveness endpoints was to be greater than 96.5% in the first interim analysis, or greater than 95.0% in other interim analyses, an early win would be declared. However, even if an early win was to be declared in a planned interim analysis, the trial would continue the enrollment of 300 patients in the randomized cohort.

B. Accountability of PMA Cohort

The enrollment into the CLASP IID trial took place between November 2018 and December 2021. A total of 300 patients were enrolled in the randomized cohort and 98 patients in the registry cohort at 54 investigational sites in the U.S., Canada, and Germany.

The first planned interim analysis of the randomized cohort included 180 patients (117 in the PASCAL system arm and 63 in the MitraClip arm) and reflected data collected through June 20, 2022. The results of this interim analysis are summarized herein and used to support the PMA approval decision.

The dispositions of the randomized patients at the time of the first planned interim analysis are detailed in Figure 9.

Figure 9: Patient Enrollment/Disposition (Randomized Cohort)

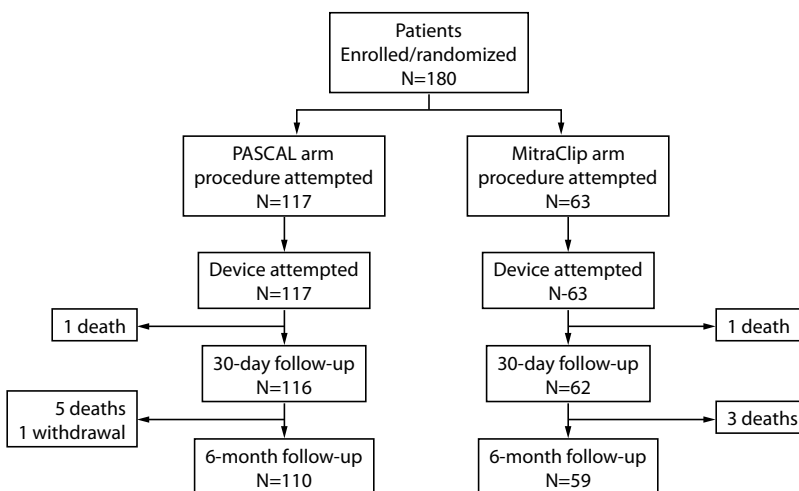

The analysis populations for the randomized cohort included: modified Intent-to-Treat (mITT) (safety) Population, mITT (effectiveness) Population, and As-Treated (AT) Population, as defined in Table 1. The primary safety and effectiveness analyses were performed on the mITT (safety) and mITT (effectiveness) populations, respectively.

Table 1: Analysis Populations (Randomized Cohort)

Analysis Population	Definition	Number of Patients	
		PASCAL	MitraClip
modified Intent-to-Treat (mITT) (safety)	All patients randomized to each treatment arm (i.e., ITT) who had the study procedure attempted (initiation of skin incision).	117	63
mITT (effectiveness)	All patients in the mITT (safety) population who had a study device attempted (insertion of the guide sheath or steerable guide into the femoral vein).	117	63

Analysis Population	Definition	Number of Patients	
		PASCAL	MitraClip
As-Treated (AT)	All patients in the mITT (effectiveness) population who had a study device attempted and implanted at the exit from procedure room.	116*	63
*One (1) patient had an aborted procedure due to inability to grasp leaflets.			

At the time of database lock, of the randomized patients eligible for the 6-month visit, 94.5% in the PASCAL system arm and 94.9% in the MitraClip arm completed the visit, as summarized in Table 2.

Table 2: Visit Compliance (Randomized Cohort) – mITT (Safety) Population

Visit Status	Randomized Cohort (N=180)			
	30 Days		6 months	
	PASCAL (N=117)	MitraClip (N=63)	PASCAL (N=117)	MitraClip (N=63)
Ineligible for visit	1	1	7	4
Eligible for visit*	116	62	110	59
Follow-up visit completed [†]	98.3% (114/116)	100.0% (62/62)	94.5% (104/110)	94.9% (56/59)
* Patients were considered eligible if they completed the visit, or their visit windows were open and they were alive and had not exited the study prior to the window opening. [†] Categorical variables: % (n/Total N)				

In the registry cohort, a total of 98 patients underwent an index procedure with the PASCAL system, 92 of whom had the study device implanted and constituted the Implanted Population. Six (6) patients did not receive a study device due to inability to grasp leaflets (n=3), increased transmitral valve gradient (n=2) or insufficient MR reduction (n=1). The visit compliance of the registry patients implanted with a study device is shown in Table 3.

Table 3: Visit Compliance (Registry Cohort) – Implanted Population

Visit Status	Registry Cohort (N=92)	
	30 Days	6 Months
Ineligible for visit	1	6
Eligible for visit*	91	86
Follow-up visit completed [†]	96.7% (88/91)	90.7% (78/86)
* Patients were considered eligible if they completed the visit, or their visit windows were open and they were alive and had not exited the study prior to the window opening. [†] Categorical variables: % (n/Total N)		

C. Study Population Demographics and Baseline Characteristics

The demographics and baseline characteristics of the study population in the randomized cohort are typical for a DMR study performed in the US, as shown in Table 4. The two treatment arms were well balanced, with no significant differences in patient demographics and baseline characteristics.

Table 4: Patient Demographics and Baseline Characteristics (Randomized Cohort) – mITT (Safety) Population

Demographics and Baseline Characteristics	Randomized Cohort Summary Statistics* (N=180)		p-value [†]
	PASCAL (N=117)	MitraClip (N=63)	
Age (years)	81.1 ± 6.87 (117)	81.2 ± 6.24 (63)	0.926
Sex at birth			
Male	66.7% (78/117)	68.3% (43/63)	0.869

Demographics and Baseline Characteristics	Randomized Cohort Summary Statistics* (N=180)		p-value †
	PASCAL (N=117)	MitraClip (N=63)	
Race			
Asian	4.3% (5/117)	1.6% (1/63)	0.598
Black or African American	2.6% (3/117)	3.2% (2/63)	
White	71.8% (84/117)	76.2% (48/63)	
Other	2.6% (3/117)	0.0% (0/63)	
Not available ‡	18.8% (22/117)	19.0% (12/63)	
Body mass index (kg/m ²)	25.9 ± 5.40 (117)	26.2 ± 4.82 (63)	0.499
New York Heart Association (NYHA) functional class			
Class I	0.9% (1/117)	0.0% (0/63)	0.573
Class II	38.5% (45/117)	38.1% (24/63)	
Class III	57.3% (67/117)	54.0% (34/63)	
Class IV	3.4% (4/117)	7.9% (5/63)	
Left ventricular ejection fraction (LVEF; %)	59.6 ± 8.68 (117)	58.3 ± 9.04 (63)	0.346
Society of Thoracic Surgeons (STS) score for mitral valve replacement (%)	5.7 ± 3.27 (117)	5.1 ± 2.58 (63)	0.437
STS score for mitral valve repair (%)	4.1 ± 2.82 (117)	3.6 ± 2.16 (63)	0.476
European System for Cardiac Operative Risk Evaluation (EuroSCORE) II (%)	3.9 ± 2.93 (117)	4.1 ± 3.09 (63)	0.736
Clinical frailty total score [§]			
≤ 3	17.9% (21/117)	15.9% (10/63)	0.837
> 3	82.1% (96/117)	84.1% (53/63)	
Cardiomyopathy	13.7% (16/117)	17.5% (11/63)	0.517
Coronary artery disease (≥ 50% stenosis)	39.3% (46/117)	39.7% (25/63)	1.000
Hypertension	83.8% (98/117)	90.5% (57/63)	0.263
Myocardial infarction	16.2% (19/117)	11.1% (7/63)	0.385
Stroke	7.7% (9/117)	1.6% (1/63)	0.169
Atrial fibrillation	57.3% (67/117)	60.3% (38/63)	0.752
Pacemaker/implantable cardioverter defibrillator	6.0% (7/117)	14.3% (9/63)	0.096
Percutaneous coronary intervention (PCI)/stent	23.1% (27/117)	22.2% (14/63)	1.000
Total number of open-heart surgeries (valve and coronary artery bypass graft)			
0	87.2% (102/117)	90.5% (57/63)	0.873
1	12.0% (14/117)	9.5% (6/63)	
2	0.9% (1/117)	0.0% (0/63)	

Demographics and Baseline Characteristics	Randomized Cohort Summary Statistics* (N=180)		p-value †
	PASCAL (N=117)	MitraClip (N=63)	
Chronic obstructive pulmonary disease (COPD)	17.1% (20/117)	19.0% (12/63)	0.838
Home oxygen use	5.1% (6/117)	4.8% (3/63)	1.000
Diabetes	16.2% (19/117)	23.8% (15/63)	0.235
Renal insufficiency or failure	35.0% (41/117)	42.9% (27/63)	0.335
Stage 1 (eGFR >= 90)	0.0% (0/117)	0.0% (0/63)	-
Stage II (eGFR 60-89)	5.1% (6/117)	4.8% (3/63)	1.000
Stage III (eGFR 30-59)	28.2% (33/117)	36.5% (23/63)	0.311
Stage IV (eGFR 15-29)	1.7% (2/117)	1.6% (1/63)	1.000
Stage V (eGFR < 15)	0.0% (0/117)	0.0% (0/63)	-
History of renal replacement therapy (e.g., dialysis)	0.9% (1/117)	0.0% (0/63)	1.000
COVID-19	0.9% (1/111)	1.7% (1/59)	1.000
Mitral regurgitation (MR) severity ≥ 3+ at baseline [‡]	100.0% (117/117)	100.0% (63/63)	-
Number of hospitalizations for heart failure in the last 12 months			
0	65.8% (77/117)	60.3% (38/63)	0.736
1	23.1% (27/117)	30.2% (19/63)	
2	7.7% (9/117)	7.9% (5/63)	
3	3.4% (4/117)	1.6% (1/63)	
Total number of days hospitalized for heart failure in the last 12 months (for those who had heart failure hospitalization)	8.6 ± 6.87 (38)	8.0 ± 6.73 (25)	0.687
*Categorical variables: % (n/Total N); continuous variables: Mean ± SD (n)			
†p-value was based on Kruskal-Wallis test for continuous variables and Fisher's Exact test for categorical variables.			
‡Race not collected for patients in Germany due to privacy regulations.			
§A clinical frailty score of ≤ 3 was inclusive of "very fit," "well," and "managing well." A clinical frailty score of > 3 was inclusive of "vulnerable," "mildly frail," "moderately frail," "severely frail," "very severely frail," and "terminally ill."			
Baseline MR severity was determined by transthoracic echocardiogram (TTE) for all patients except for 2 patients determined by transesophageal echocardiogram (TEE).			

All patients in the CLASP IID trial were required to be at prohibitive risk for surgical mitral valve repair or replacement per the local heart team. Reasons for prohibitive risk are summarized in Table 5 for the randomized cohort. The most common reason for prohibitive risk for both treatment arms was frailty as assessed by a cardiac surgeon using the Canadian Study of Health and Aging (CSHA) Frailty Scale (84.6% in the PASCAL system arm and 90.5% in the MitraClip arm).

Table 5: Reasons for Prohibitive Risk (Randomized Cohort) – mITT (Safety) Population

Prohibitive Risk Factors*	Summary Statistics [†]	
	PASCAL (N=117)	MitraClip (N=63)
Society of Thoracic Surgeons (STS) predicted mortality risk score for mitral valve replacement: ≥ 8%	21.4% (25/117)	14.3% (9/63)
STS predicted mortality risk score for mitral valve repair: ≥ 6%	17.9% (21/117)	9.5% (6/63)

Prohibitive Risk Factors*	Summary Statistics†	
	PASCAL (N=117)	MitraClip (N=63)
Porcelain aorta or extensively calcified ascending aorta	1.7% (2/117)	0.0% (0/63)
Frailty (assessed by in-person cardiac surgeon consultation)	84.6% (99/117)	90.5% (57/63)
Hostile chest	6.0% (7/117)	6.3% (4/63)
Severe liver disease/cirrhosis (Model for End-Stage Liver Disease score > 12)	0.0% (0/117)	1.6% (1/63)
Severe pulmonary hypertension (systolic pulmonary artery pressure > 2/3 systemic pressure)	2.6% (3/117)	4.8% (3/63)
Right ventricular dysfunction	0.9% (1/117)	1.6% (1/63)
Chemotherapy for malignancy	1.7% (2/117)	1.6% (1/63)
Immobility	11.1% (13/117)	12.7% (8/63)
Acquired immunodeficiency syndrome (AIDS)	0.0% (0/117)	0.0% (0/63)
High risk of aspiration	3.4% (4/117)	7.9% (5/63)
Internal mammary artery (IMA) at high risk of injury	1.7% (2/117)	0.0% (0/63)
Other	28.2% (33/117)	22.2% (14/63)
* At baseline, patients may present with more than one prohibitive risk factor.		
†Categorical variables: % (n/Total N)		

The demographics and baseline characteristics of the study population in the registry cohort are summarized in Table 6.

Table 6: Patient Demographics and Baseline Characteristics (Registry Cohort) – Implanted Population

Demographics and Baseline Characteristics	Registry Cohort Summary Statistics* (N=92)
Age (years)	81.4 ± 6.41 (92)
Sex at birth	
Male	62.0% (57/92)
Race	
Asian	3.3% (3/92)
Black or African American	4.3% (4/92)
White	72.8% (67/92)
Other	4.3% (4/92)
Not available†	15.2% (14/92)
Body mass index (kg/m ²)	25.5 ± 4.43 (92)
New York Heart Association (NYHA) functional class	
Class I	3.3% (3/92)
Class II	28.3% (26/92)
Class III	64.1% (59/92)
Class IV	4.3% (4/92)
Left ventricular ejection fraction (LVEF; %)	58.7 ± 10.58 (92)
Society of Thoracic Surgeons (STS) score for mitral valve replacement (%)	6.6 ± 4.90 (92)

Demographics and Baseline Characteristics	Registry Cohort Summary Statistics* (N=92)
STS score for mitral valve repair (%)	4.6 ± 4.07 (92)
European System for Cardiac Operative Risk Evaluation (EuroSCORE) II (%)	5.0 ± 4.34 (92)
Clinical frailty total score [‡]	
≤ 3	17.4% (16/92)
> 3	82.6% (76/92)
Cardiomyopathy	19.6% (18/92)
Coronary artery disease (≥ 50% stenosis)	43.5% (40/92)
Hypertension	83.7% (77/92)
Myocardial infarction	16.3% (15/92)
Stroke	5.4% (5/92)
Atrial fibrillation	68.5% (63/92)
Pacemaker/implantable cardioverter defibrillator	16.3% (15/92)
Percutaneous coronary intervention (PCI)/stent	21.7% (20/92)
Total number of open-heart surgeries (valve and coronary artery bypass graft)	
0	81.5% (75/92)
1	17.4% (16/92)
2	1.1% (1/92)
Chronic obstructive pulmonary disease (COPD)	14.1% (13/92)
Home oxygen use	7.6% (7/92)
Diabetes	19.6% (18/92)
Renal insufficiency or failure	51.1% (47/92)
Stage I (eGFR ≥ 90)	0.0% (0/92)
Stage II (eGFR 60-89)	5.4% (5/92)
Stage III (eGFR 30-59)	39.1% (36/92)
Stage IV (eGFR 15-29)	6.5% (6/92)
Stage V (eGFR < 15)	0.0% (0/92)
History of renal replacement therapy (e.g., dialysis)	0.0% (0/92)
COVID-19	3.4% (3/89)
Mitral regurgitation (MR) severity ≥ 3+ at baseline [§]	100.0% (92/92)
Number of hospitalizations for heart failure in the last 12 months	
0	62.6% (57/91)
1	23.1% (21/91)
2	8.8% (8/91)
3	4.4% (4/91)
4	1.1% (1/91)

Demographics and Baseline Characteristics	Registry Cohort Summary Statistics* (N=92)
Total number of days hospitalized for heart failure in the last 12 months (for those who had heart failure hospitalization)	7.9 ± 8.49 (33)
*Categorical variables: % (n/Total N); continuous variables: Mean ± SD (n) †Race not collected for patients in Germany due to privacy regulations. ‡A clinical frailty score of ≤ 3 was inclusive of "very fit," "well," and "managing well." A clinical frailty score of > 3 was inclusive of "vulnerable," "mildly frail," "moderately frail," "severely frail," "very severely frail," and "terminally ill." §Baseline MR severity was determined by transthoracic echocardiogram (TTE) for all patients except for 2 patients determined by transesophageal echocardiogram (TEE).	

The anatomical criteria of patients in the registry cohort that rendered the patients ineligible for randomization are summarized in Table 7. The most common anatomical complexity was the presence of two or more independent significant jets (42.4%), followed by evidence of severe bileaflet/multi-scallop prolapse involvement (17.4%), mitral valve orifice area < 4.0 cm² (15.2%), and large flail gap (> 10 mm) and/or flail width (> 15 mm) (13.0%). A total of 83.7% of patients met 1 anatomical complexity criterion and 16.3% met 2 criteria.

Table 7: Anatomical Criteria (Registry Cohort) – Implanted Population

Anatomical Criteria	Summary Statistics* (N=92)
Presence of two or more independent significant jets	42.4% (39/92)
Evidence of severe bileaflet/multi-scallop prolapse involvement	17.4% (16/92)
Mitral valve orifice area < 4.0 cm ²	15.2% (14/92)
Large flail gap (> 10 mm) and/or large flail width (> 15 mm) [†]	13.0% (12/92)
Presence of one significant jet in the commissural area	12.0% (11/92)
Presence of significant cleft or perforation in the grasping area	6.5% (6/92)
Leaflet mobility length < 8 mm	4.3% (4/92)
Evidence of moderate to severe calcification in the grasping area	4.3% (4/92)
History of endocarditis and significant tissue defects in the leaflet [†]	1.1% (1/92)
Total number of anatomical criteria met	
1	87.3% (77/92)
2	16.3% (15/92)
*Categorical variables: % (n/Total N); patients can be counted in more than one anatomical criterion category. †Anatomical criterion not pre-specified in the study protocol but identified by the Central Screening Committee as an anatomical criterion that made valve anatomy suitable for a PASCAL implant, but not for a MitraClip implant.	

D. Safety and Effectiveness Results

This section summarizes the results of the first planned interim analysis of the randomized cohort, along with the results of the registry cohort. For brevity, only select results of the registry cohort are presented.

1. Primary Safety Endpoint

The primary safety endpoint results for the randomized cohort are presented in Table 8. The proportion of patients with MAEs at 30 days was 3.4% in the PASCAL system arm and 4.8% in the MitraClip arm, with a rate difference (PASCAL system - MitraClip) of -1.3%. Since the one-sided 95% upper confidence bound of the rate difference was 5.1%, which was lower than the pre-specified non-inferiority margin of 15%, the primary safety endpoint was met.

Table 8: MAEs at 30 Days (Randomized Cohort) – mITT (Safety) Population

Variable	PASCAL (N=117)		MitraClip (N=63)	
	No. Events	Patients* % (n/N)	No. Events	Patients % (n/N)
Composite major adverse events (MAEs)	5	3.4% (4/116)	3	4.8% (3/63)
Cardiovascular death	1	0.9% (1/116)	1	1.6% (1/63)
Stroke	0	0.0% (0/116)	0	0.0% (0/63)
Myocardial infarction	0	0.0% (0/116)	0	0.0% (0/63)
New need for renal replacement therapy	0	0.0% (0/116)	0	0.0% (0/63)
Severe bleeding	3	2.6% (3/116)	2	3.2% (2/63)
Non-elective mitral valve re-intervention	1	0.9% (1/116)	0	0.0% (0/63)
Composite rate difference (PASCAL - MitraClip)	-1.3%			
One-sided 95% upper confidence bound [†]	5.1%			
Non-inferiority margin	15.0%			
Non-inferiority test	Success			
*One (1) patient who was excluded from the denominator was not followed for at least 30 days and did not have an MAE at the time of the last follow-up.				
†One-sided 95% upper confidence bound was based on unpooled Z test with continuity correction.				

The primary safety endpoint results for the registry cohort are summarized in Table 9. The proportion of patients with MAEs at 30 days was 8.7%.

Table 9: MAEs at 30 Days (Registry Cohort) – Implanted Population

Variable	No. Events	Patients % (n/N)
Composite MAE	9	8.7% (8/92)
Cardiovascular death	1	1.1% (1/92)
Stroke	1	1.1% (1/92)
Myocardial infarction	1	1.1% (1/92)
New need for renal replacement therapy	1	1.1% (1/92)
Severe bleeding	4	4.3% (4/92)
Non-elective mitral valve re-intervention	1	1.1% (1/92)

2. Primary Effectiveness Endpoint

The primary effectiveness endpoint results for the randomized cohort are presented in Table 10. The proportion of patients with MR ≤ 2+ at 6 months was 96.5% in the PASCAL system arm and 96.8% in the MitraClip arm. The rate difference between the PASCAL system arm and the MitraClip arm was -0.3%, with a one-sided 95% lower confidence bound of -6.2%, which was greater than the pre-specified non-inferiority margin of -18%. Thus, the primary effectiveness endpoint was met.

Table 10: Proportion of Patients with MR ≤ 2+ at 6 Months (Randomized Cohort) – mITT (Effectiveness) Population

Variable	Randomized Cohort (N=180)	
	PASCAL (N=117)	MitraClip (N=63)
MR ≤ 2+; % (n/N)*	96.5% (110/114)	96.8% (60/62)
Rate difference (PASCAL - MitraClip)	-0.3%	
One-sided 95% lower confidence bound†	-6.2%	
Non-inferiority margin	-18.0%	
Non-inferiority test	Success	
*Of the 117 patients in the PASCAL system mITT (effectiveness) population, data for 3 patients were unavailable for the primary effectiveness analysis, including 2 patients who died prior to reaching the 30-day follow-up and 1 patient who was missing their 30-day and 6-month follow-up due to residing outside of the U.S. at the time. Of the 63 patients in the MitraClip mITT (effectiveness) population, data for 1 patient were unavailable for the primary effectiveness analysis due to patient death prior to the 30-day follow-up.		
†One-sided 95% lower confidence bound was based on unpooled Z test with continuity correction.		

The primary effectiveness endpoint results for the registry cohort are presented in Table 11. The proportion of patients with MR ≤ 2+ at 6 months was 91.0%.

Table 11: Proportion of Patients with MR ≤ 2+ at 6 Months (Registry Cohort) - Implanted Population

Variable	Registry Cohort (N=92)
MR ≤ 2+; % (n/N)*	91.0% (81/89)
* Of the 92 patients in the Implanted Population of the registry cohort, data for 3 patients were unavailable for the primary effectiveness analysis, including 2 patients who died prior to completing the 30-day follow-up and 1 patient who missed the 30-day and 6-month follow-up visits (patient died on postoperative day 225).	

3. Secondary Endpoints

Safety Endpoints

The results of various pre-defined secondary safety endpoints available at 30 days and 6 months are presented in Table 12 and Table 13 for the randomized cohort and registry cohort, respectively.

Table 12: Secondary Safety Endpoints (Randomized Cohort) – mITT (Safety) Population

Event	Rate*					
	Discharge		30 Days		6 Months	
	PASCAL (N=117)	MitraClip (N=63)	PASCAL (N=117)	MitraClip (N=63)	PASCAL (N=117)	MitraClip (N=63)
Major adverse events	-	-	-	-	6.1% (8, 7)	11.1% (9, 7)
All-cause mortality	-	-	1.7% (2, 2)	1.6% (1, 1)	5.1% (6, 6)	6.3% (4, 4)
Heart failure hospitalization	-	-	0% (0, 0)	1.6% (1, 1)	1.7% (3, 2)	3.2% (2, 2)
New onset of permanent atrial fibrillation	-	-	0% (0, 0)	0% (0, 0)	-	-
Non-elective mitral valve re-intervention (either percutaneous or surgical)	-	-	-	-	1.8% (2, 2)	1.6% (1, 1)
Residual atrial septal defect; % (n/Total N)	-	-	72.5% (50/69)	79.5% (31/39)	51.0% (26/51)	62.1% (18/29)

Event	Rate*					
	Discharge		30 Days		6 Months	
	PASCAL (N=117)	MitraClip (N=63)	PASCAL (N=117)	MitraClip (N=63)	PASCAL (N=117)	MitraClip (N=63)
Transfusion of ≥ 2 units of whole blood or packed red blood cells; % (n/Total N)	0% (0/117)	1.6% (1/63)	-	-	-	-
Gastrointestinal complications requiring surgery	-	-	0% (0, 0)	0% (0, 0)	-	-

*Kaplan-Meier rate (no. of events, no. of patients with the event), unless noted otherwise.

Table 13: Secondary Safety Endpoints (Registry Cohort) – Implanted Population

Event	Rate* (N=92)		
	Discharge	30 Days	6 Months
Major adverse events	-	-	12.0% (15, 11)
All-cause mortality	-	2.2% (2, 2)	6.5% (6, 6)
Heart failure hospitalization	-	5.5% (6, 5)	6.6% (9, 6)
New onset of permanent atrial fibrillation	-	0% (0, 0)	-
Non-elective mitral valve re-intervention (either percutaneous or surgical)	-	-	1.1% (1, 1)
Residual atrial septal defect; % (n/Total N)	-	80.6% (50/62)	73.7% (28/38)
Transfusion of ≥ 2 units of whole blood or packed red blood cells; % (n/Total N)	2.2% (2/92)	-	-
Gastrointestinal complications requiring surgery	-	0% (0, 0)	-

*Kaplan-Meier rate (no. of events, no. of patients with the event), unless noted otherwise.

6MWT Distance

The results for the 6MWT in the randomized cohort are presented in Figure 10. In the PASCAL system arm, the mean 6MWT distance increased about 30 m at 30 days compared to baseline, which was sustained through 6 months. A generally similar trend was observed in the MitraClip arm, with an improvement of about 50 m at 30 days and 40 m at 6 months.

Figure 10: 6MWT Distance by Visit (Randomized Cohort) – mITT (Effectiveness) Population

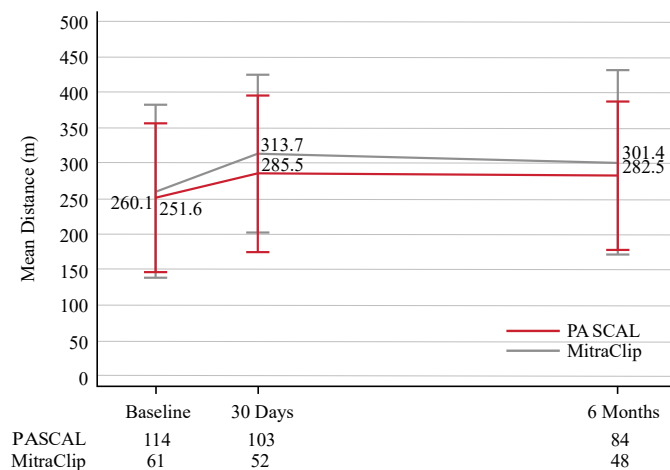

Note: The error bars represent standard deviations.

QoL

• KCCQ

The results for the KCCQ overall summary score are presented in Figure 11 for the randomized cohort. The mean score increased from 55.6 at baseline to 71.8 at 30 days and 73.8 at 6 months in the PASCAL system arm and from 60.0 at baseline to 80.1 at 30 days and 79.0 at 6 months in the MitraClip arm.

Figure 11: KCCQ Overall Summary Score by Visit (Randomized Cohort) – mITT (Effectiveness) Population

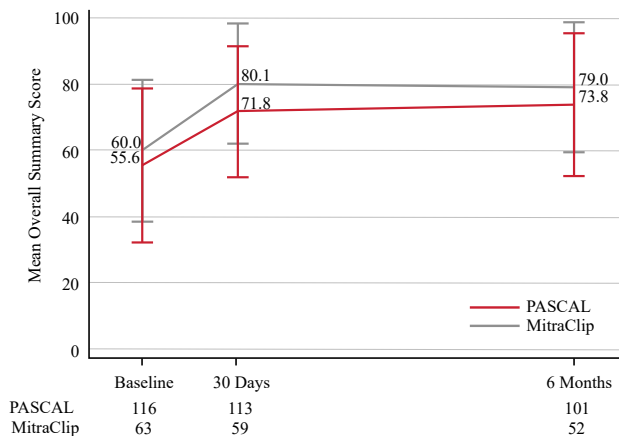

Note: The error bars represent standard deviations.

• SF-36

The results for the SF-36 physical component summary score and mental component summary score are presented in Figure 12 and Figure 13, respectively, for the randomized cohort. In the two treatment arms, the mean SF-36 physical component scores increased about 1-4 points at 30 days and 6 months compared to the baseline; the corresponding mean SF-36 mental component scores increased about 2-4 points.

Figure 12: SF-36 Physical Component Summary Score by Visit (Randomized Cohort) – mITT (Effectiveness) Population

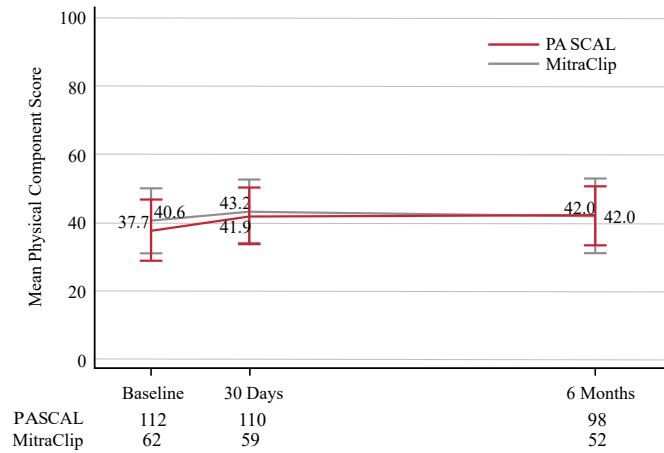

Note: The error bars represent standard deviations.

Figure 13: SF-36 Mental Component Summary Score by Visit (Randomized Cohort) – mITT (Effectiveness) Population

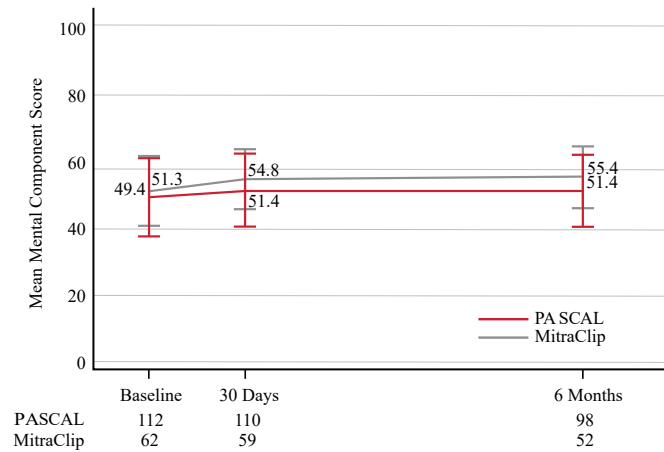

Note: The error bars represent standard deviations.

• EQ-5D-5L

The results for the EQ-5D-5L visual analog score (VAS) are presented in Figure 14 for the randomized cohort. The mean scores in the two treatment arms increased similarly in an approximate range of 8-12 points at 30 days and at 6 months compared to the baseline.

Figure 14: EQ-5D-5L Visual Analog Score by Visit (Randomized Cohort) – mITT (Effectiveness) Population

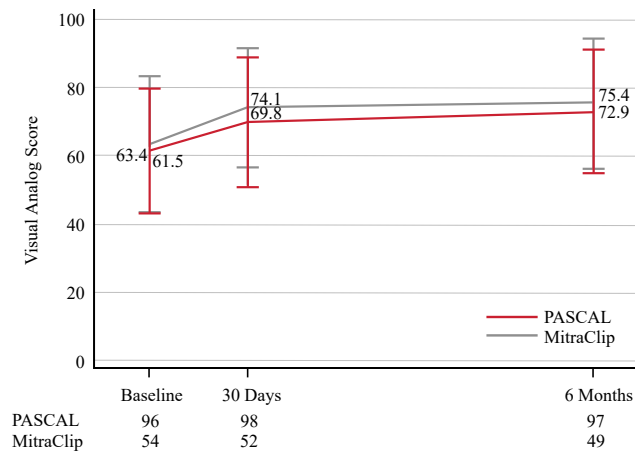

Note: The error bars represent standard deviations.

4. Adverse Events

The site-reported device- or procedure-related serious adverse events that occurred through 6 months in the randomized cohort are presented in Table 14.

Table 14: Site-Reported Device- or Procedure-related Serious Adverse Events (Randomized Cohort) – mITT (Safety) Population

Event	30 Days				6 Months			
	PASCAL (N=117)		MitraClip (N=63)		PASCAL (N=117)		MitraClip (N=63)	
	No. Events	Patients % (n/N)	No. Events	Patients % (n/N)	No. Events	Patients % (n/N)	No. Events	Patients % (n/N)
Acute kidney injury	1	0.9% (1/117)	0	0.0% (0/63)	1	0.9% (1/117)	0	0.0% (0/63)
Anemia	0	0.0% (0/117)	1	1.6% (1/63)	0	0.0% (0/117)	1	1.6% (1/63)
Atrial fibrillation	2	1.7% (2/117)	0	0.0% (0/63)	2	1.7% (2/117)	0	0.0% (0/63)
Atrioventricular block second degree	1	0.9% (1/117)	0	0.0% (0/63)	1	0.9% (1/117)	0	0.0% (0/63)
Cardiac failure acute	0	0.0% (0/117)	1	1.6% (1/63)	0	0.0% (0/117)	2	3.2% (2/63)
Cardiac procedure complication	0	0.0% (0/117)	0	0.0% (0/63)	0	0.0% (0/117)	1	1.6% (1/63)
Cardiogenic shock	0	0.0% (0/117)	1	1.6% (1/63)	0	0.0% (0/117)	1	1.6% (1/63)
Chest pain	1	0.9% (1/117)	0	0.0% (0/63)	1	0.9% (1/117)	0	0.0% (0/63)
Hypervolemia	0	0.0% (0/117)	1	1.6% (1/63)	0	0.0% (0/117)	1	1.6% (1/63)
Hyponatremia	1	0.9% (1/117)	0	0.0% (0/63)	1	0.9% (1/117)	0	0.0% (0/63)
Hypotension	2	1.7% (2/117)	0	0.0% (0/63)	2	1.7% (2/117)	0	0.0% (0/63)
Leukocytosis	1	0.9% (1/117)	1	1.6% (1/63)	1	0.9% (1/117)	1	1.6% (1/63)
Lip injury	0	0.0% (0/117)	1	1.6% (1/63)	0	0.0% (0/117)	1	1.6% (1/63)
Lower gastrointestinal hemorrhage	1	0.9% (1/117)	0	0.0% (0/63)	1	0.9% (1/117)	0	0.0% (0/63)
Mitral valve incompetence	2	1.7% (2/117)	2	3.2% (2/63)	3	2.6% (3/117)	2	3.2% (2/63)
Muscular weakness	0	0.0% (0/117)	1	1.6% (1/63)	0	0.0% (0/117)	1	1.6% (1/63)
Septic shock	0	0.0% (0/117)	1	1.6% (1/63)	0	0.0% (0/117)	1	1.6% (1/63)
Small intestinal obstruction	0	0.0% (0/117)	1	1.6% (1/63)	0	0.0% (0/117)	1	1.6% (1/63)
Vascular pseudoaneurysm	1	0.9% (1/117)	0	0.0% (0/63)	1	0.9% (1/117)	0	0.0% (0/63)

5. Other Study Observations

MR Severity Grade

The MR severity grades by visit are presented in Figure 15 for the randomized cohort. The proportion of patients with MR $\geq 3+$ decreased from 100% at baseline to 2.1% at 6 months in the PASCAL system arm compared to 100% at baseline to 1.9% at 6 months in the MitraClip arm.

Figure 15: MR Severity Grade by Visit (Randomized Cohort) – mITT (Effectiveness) Population

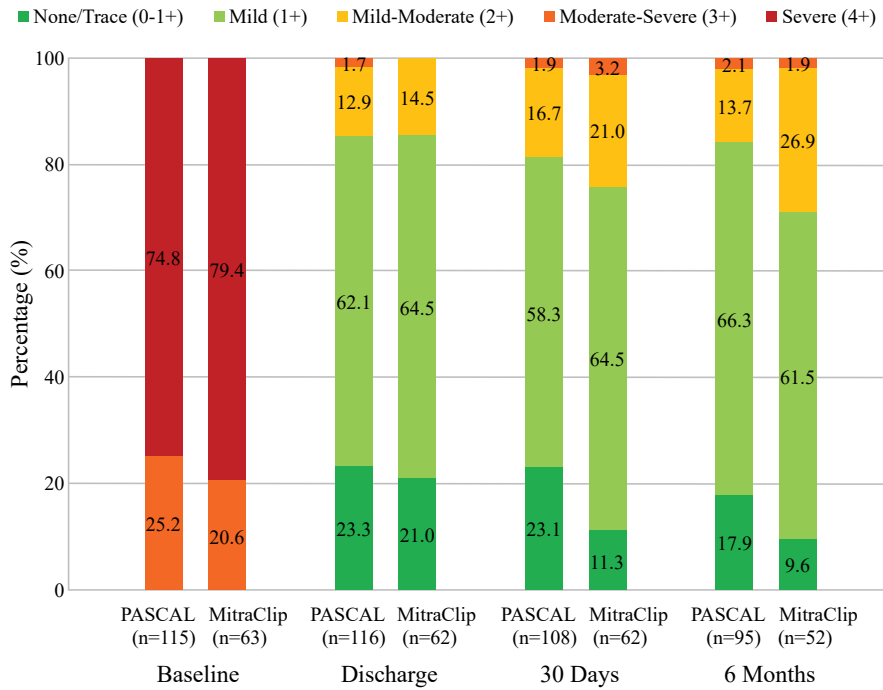

The MR severity grades by visit, as measured by TTE, in the registry cohort are presented in Figure 16. At 6 months, only 9.9% of the patients had MR $\geq 3+$ at 6 months compared to 100% at baseline.

Figure 16: MR Severity Grade by Visit (Registry Cohort) – Implanted Population

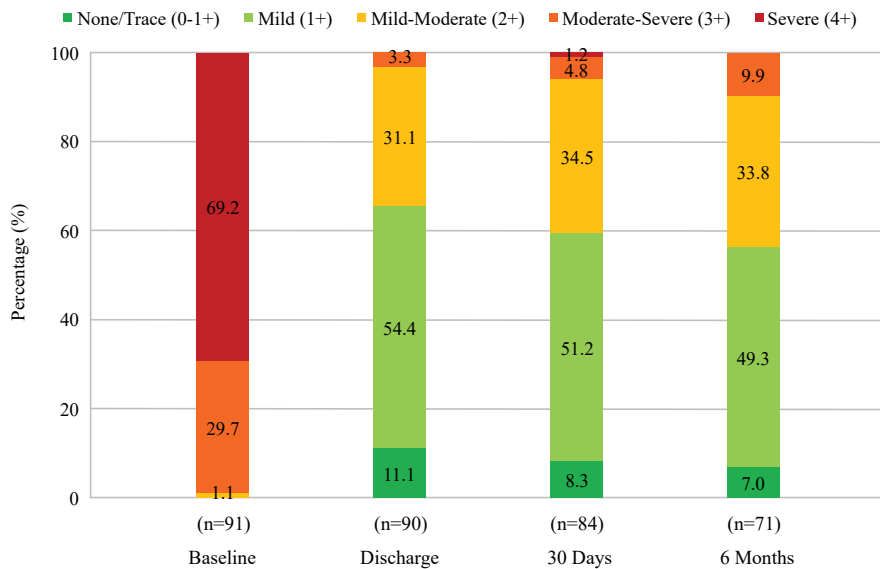

NYHA Functional Class

The NYHA classifications by visit are presented in Figure 17 for the randomized cohort. At baseline, 60.7% of PASCAL system patients and 61.9% of MitraClip patients were in NYHA class III/IV. The proportion of patients in NYHA class III/IV decreased to 13.9% in the PASCAL system patients and 5.4% in the MitraClip patients at 6 months.

Figure 17: NYHA Class by Visit (Randomized Cohort) – mITT (Effectiveness) Population

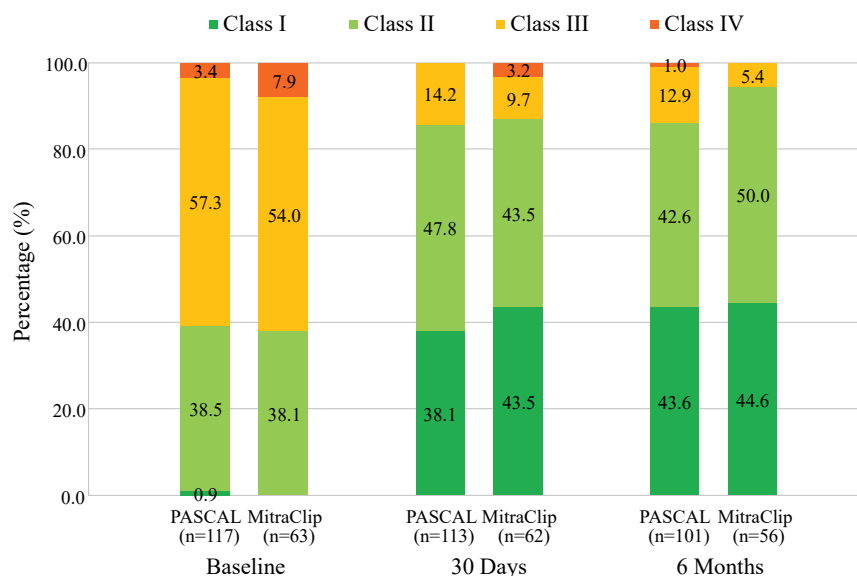

Echocardiographic Parameters

Key echocardiographic parameters for the randomized cohort are summarized in Table 15.

Table 15: Echocardiographic Parameters by TTE (Randomized Cohort)- mITT (Effectiveness) Population

Parameter	Visit	Summary Statistic*	
		PASCAL (N=117)	MitraClip (N=63)
Left ventricular end-diastolic diameter (LVEDD; mm)	Baseline	57.1 ± 6.54 (117)	57.4 ± 6.50 (63)
	Discharge †	54.2 ± 6.72 (111)	56.0 ± 5.77 (59)
	30 days	53.2 ± 6.58 (108)	54.8 ± 6.43 (59)
	6 months	51.5 ± 8.02 (89)	53.5 ± 6.39 (50)
Left ventricular end-systolic diameter (LVESD; mm)	Baseline	38.3 ± 7.66 (116)	39.8 ± 7.83 (62)
	Discharge †	38.0 ± 7.62 (108)	40.3 ± 7.44 (58)
	30 days	37.3 ± 7.21 (106)	40.0 ± 9.80 (58)
	6 months	36.0 ± 7.25 (88)	37.4 ± 6.92 (49)
Ejection fraction (%)	Baseline	59.6 ± 8.68 (117)	58.3 ± 9.04 (63)
	Discharge †	57.1 ± 7.97 (116)	54.8 ± 8.98 (62)
	30 days	57.7 ± 7.34 (108)	55.4 ± 8.27 (62)
	6 months	56.4 ± 7.71 (95)	55.8 ± 7.27 (52)
Transmitral antegrade mean gradient (mmHg)	Baseline	2.5 ± 1.14 (113)	2.4 ± 1.06 (59)
	Discharge †	3.8 ± 1.54 (115)	3.6 ± 1.36 (62)
	30 days	3.7 ± 1.67 (108)	3.6 ± 1.56 (62)
	6 months	3.7 ± 1.68 (92)	3.4 ± 1.33 (51)

*Continuous variables: Mean ± SD (n)

†Discharge or Day 7, whichever occurred first.

Cardiovascular Mortality

The Kaplan-Meier curves for cardiovascular mortality are shown in Figure 18 for the randomized cohort.

Figure 18: Cardiovascular Mortality Through 6 Months (Randomized Cohort) - mITT (Safety) Population

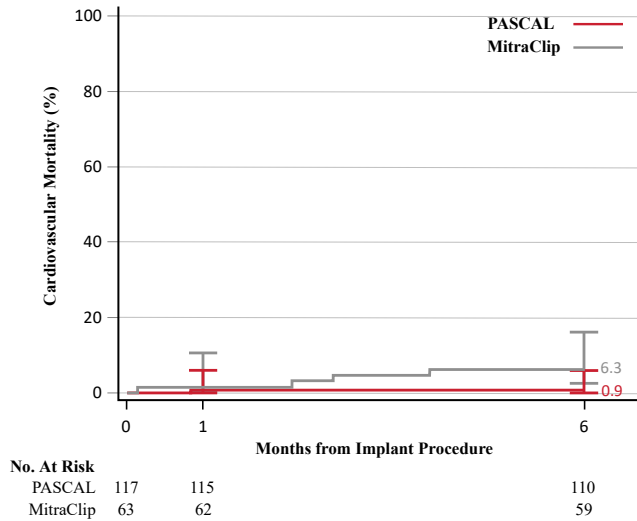

Note: The confidence intervals were calculated without multiplicity adjustment. The adjusted confidence intervals could be wider than presented here. As such, confidence intervals are provided to illustrate the variability only and should not be used to draw any statistical conclusion.

Procedural Data

The general procedural data for the randomized cohort are summarized in Table 16.

Table 16: General Procedural Data (Randomized Cohort) - AT Population

Procedural Data	Summary Statistics*	
	PASCAL (N=116)	MitraClip (N=63)
General anesthesia	100.0% (116/116)	100.0% (63/63)
Implant rate [†]	100.0% (116/116)	100.0% (63/63)
Number of implanted devices	1.5 ± 0.57 (116) 1.0 (1.0, 3.0)	1.6 ± 0.68 (63) 2.0 (1.0, 3.0)
1	54.3% (63/116)	47.6% (30/63)
2	42.2% (49/116)	41.3% (26/63)
3	3.4% (4/116)	11.1% (7/63)
Total procedure time (min) [‡]	101.0 ± 49.42 (115) 88.0 (33.0, 357.0)	84.3 ± 37.14 (62) 79.0 (25.0, 174.0)
Device time (min) [§]	71.9 ± 45.27 (116) 59.5 (6.0, 232.0)	50.0 ± 31.72 (61) 41.0 (5.0, 144.0)
Fluoroscopy duration (min)	26.3 ± 15.99 (114) 23.0 (3.0, 79.0)	22.9 ± 14.39 (63) 20.0 (0.0, 75.0)
Total length of stay in days for the index hospitalization (from procedure date)	2.2 ± 2.82 (116) 1.0 (1.0, 20.0)	1.8 ± 1.45 (63) 1.0 (0.0, 7.0)

*Continuous variables: Mean ± SD (n); median (min, max). Categorical variables: % (n/Total N).
[†]Implant rate: % of patients who had study device implanted, deployed as intended, and delivery system retrieved successfully.
[‡]Total procedure time: from procedure start time (femoral vein puncture/skin incision) to femoral vein access closure.
[§]Device time: from implant system insertion to removal.

Figures

AT065

AT070

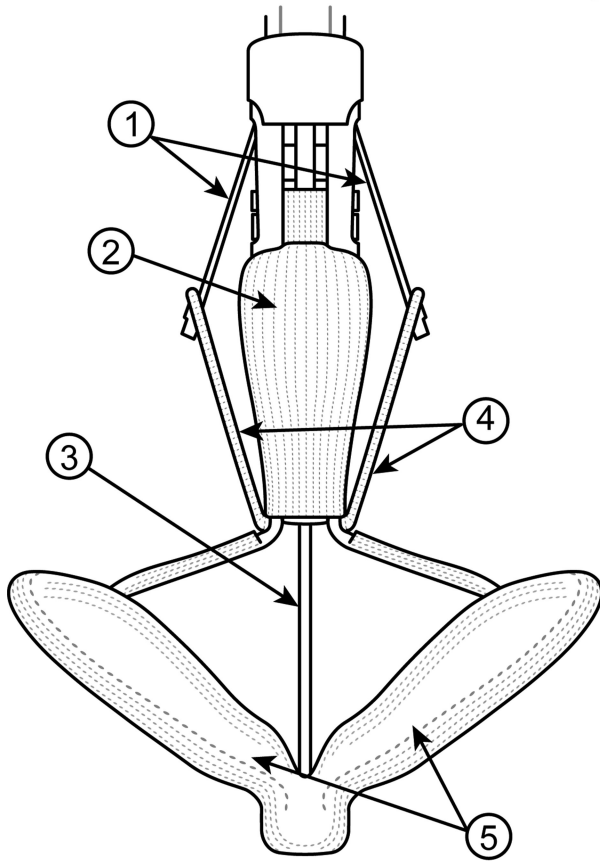

PASCAL

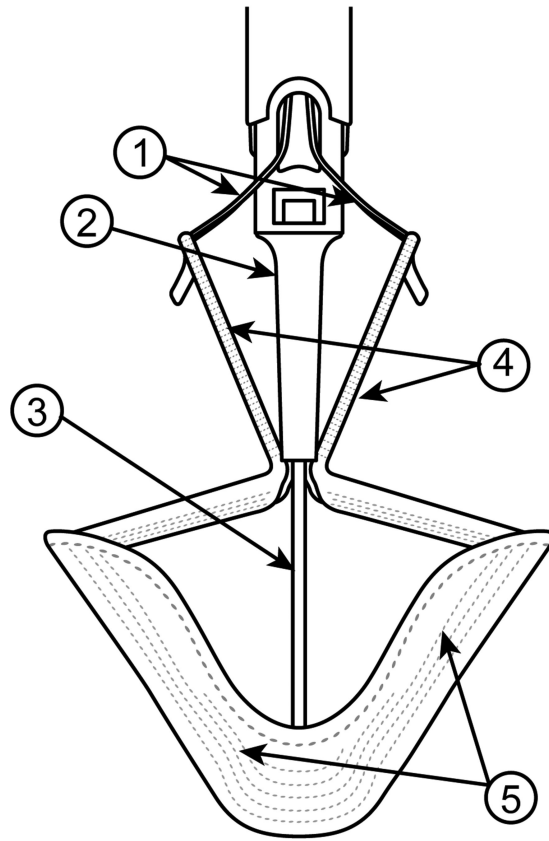

PASCAL Ace

- 1. Sutures
- 2. Spacer
- 3. Actuation Wire
- 4. Clasps
- 5. Paddles

Figure 1: Implant

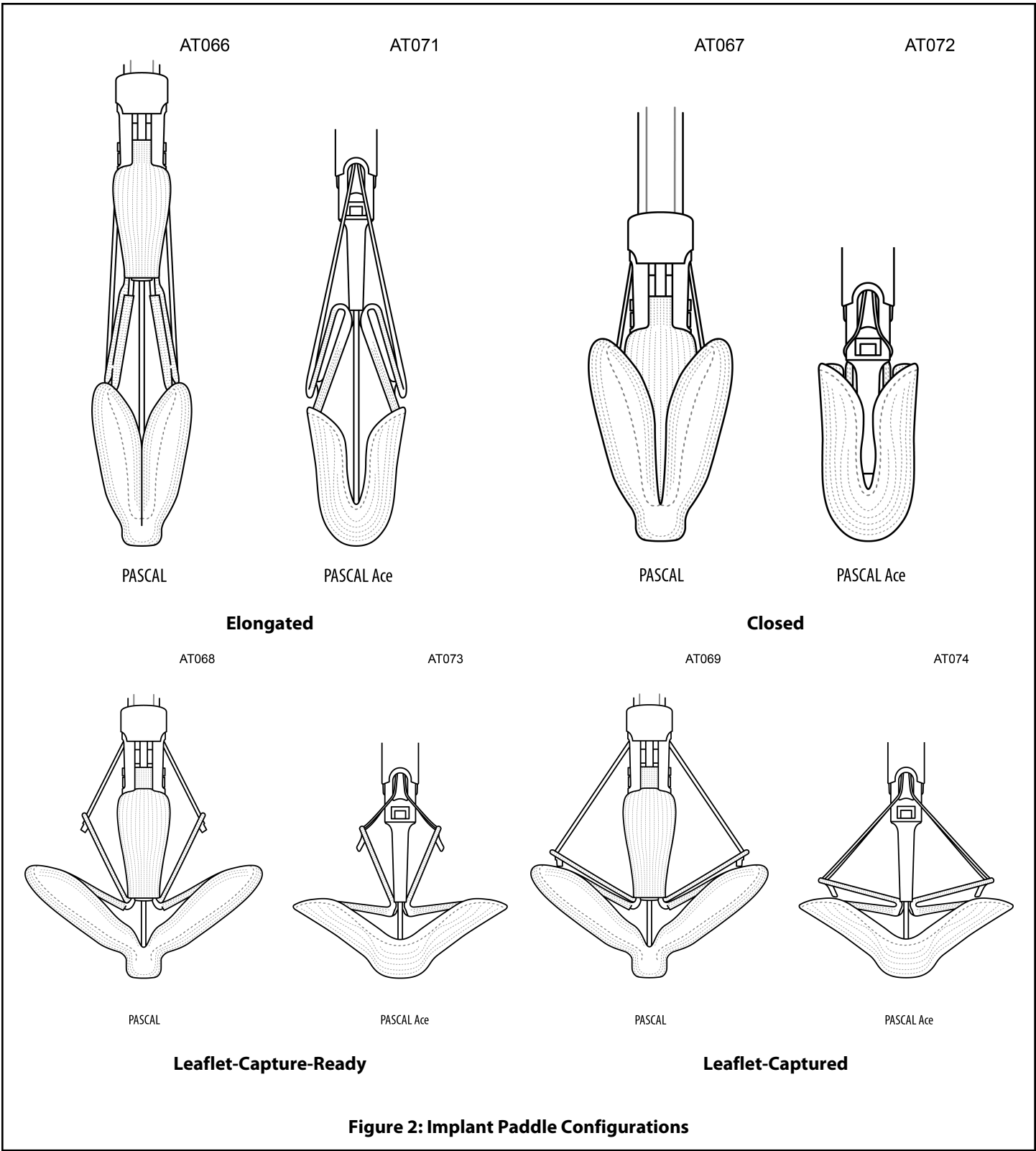

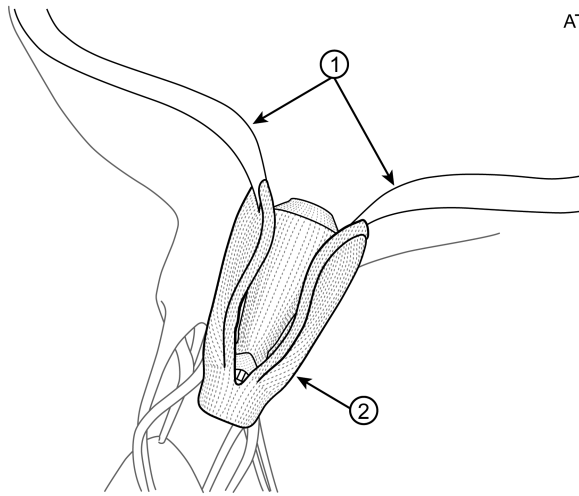

Note: Figure 3 is representative of both 20000IS and 20000ISM Implants.

- 1. Leaflets
- 2. Implant

Figure 3: Implant in Final Implanted Position

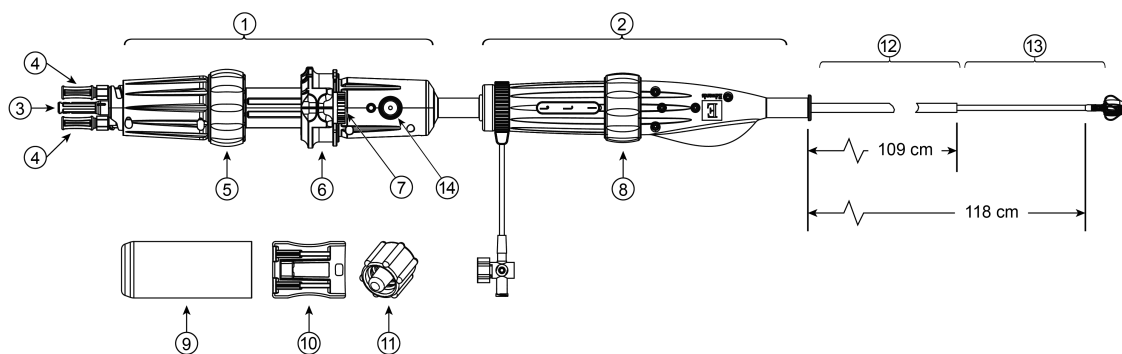

1. Implant Catheter Handle
2. Steerable Catheter Handle
3. Implant Release Knob
4. Suture Locks
5. Paddle Knob
6. Clasp Sliders
7. Clasp Lock
8. Flex Knob
9. Implant Release Cover
10. Clasp Setting Tool
11. Flush Port Cap
12. Steerable Catheter
13. Implant Catheter
14. Vented Cap

Figure 4: Implant System

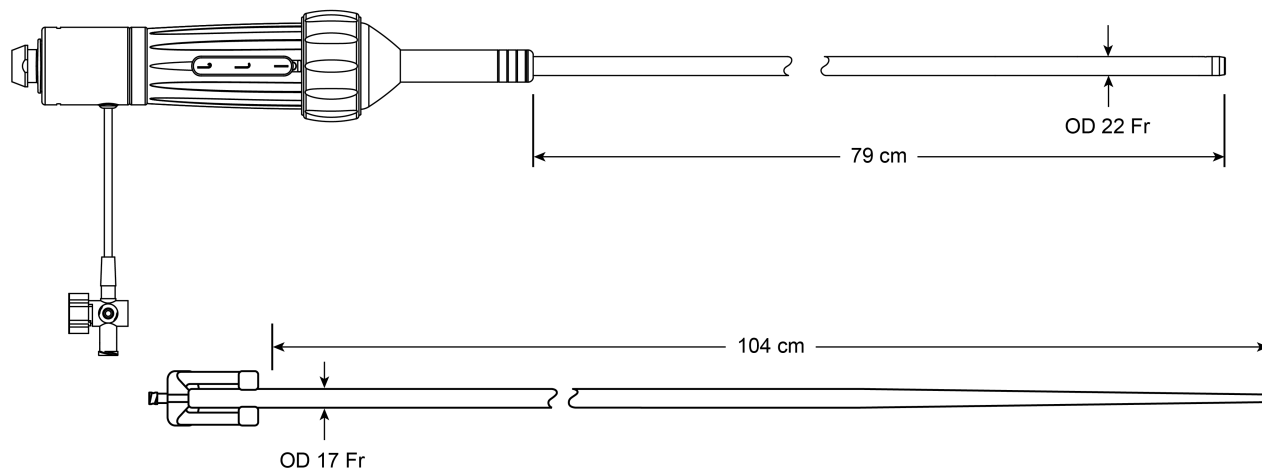
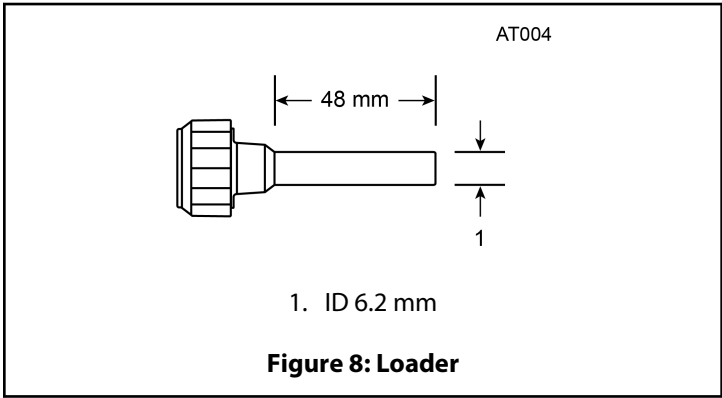
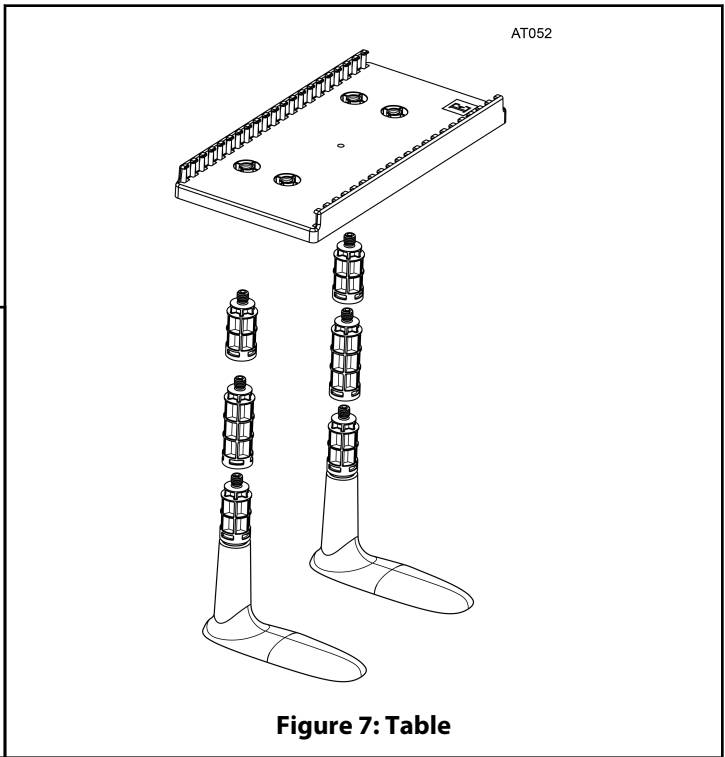
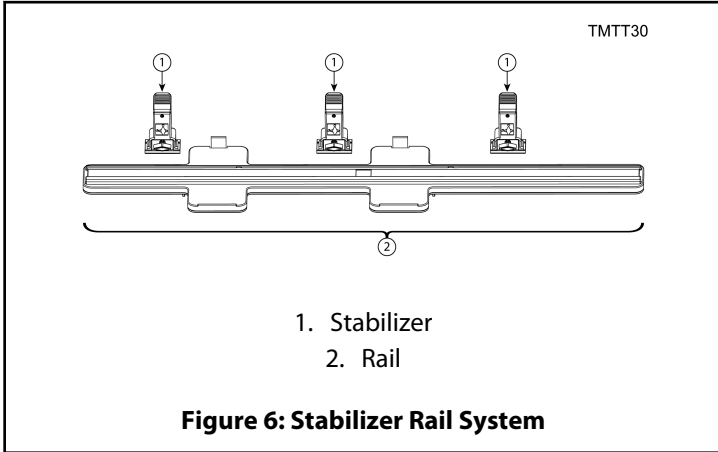

Figure 5: Guide Sheath and Introducer



Symbol Legend

	English
	Model Number
	Catalogue Number
	Quantity
	Lot Number
	Contents
	Usable length
	Do not re-use
	Caution
	Consult instructions for use or consult electronic instructions for use
	Do not use if package is damaged and consult instructions for use
	Store in a cool, dry place
	Keep away from sunlight
	Keep dry
	Medical device
	Single sterile barrier system
	Consult instructions for use on the website

	English
	Caution: Federal (USA) law restricts this device to sale by or on the order of a physician.
	Sterilized using ethylene oxide
	Sterilized using irradiation
	Sterilized using liquid chemical
	Do not re-sterilize
	Non-sterile
	Non-pyrogenic
	Non-DEHP
	Use-by date
	Serial Number
	Authorized representative in the European Community/European Union
	Manufacturer
	Date of manufacture
	For use with size 44 mm Edwards transcatheter heart valve

	English
	For use with size 48 mm Edwards transcatheter heart valve
	For use with size 52 mm Edwards transcatheter heart valve
	Temperature limit
	Exterior diameter
	Inner diameter
	Recommended guidewire length
	Recommended guidewire size
	Guidewire compatibility
	Size
	Catheter shaft size
	Balloon diameter
	Balloon working length
	[Implant only] The implant device had been determined to be MR Conditional when used under the conditions listed in the instructions.
	MR Unsafe
	Unique device identifier

Note: The labeling of this product may not contain every symbol depicted in this legend.



Edwards

10/2024

10051562005 A

© Copyright 2024, Edwards Lifesciences LLC

All rights reserved.



Edwards Lifesciences LLC
One Edwards Way
Irvine, CA 92614 USA

Telephone +1.949.250.2500

+1.800.424.3278

FAX +1.949.250.2525

Web IFU