

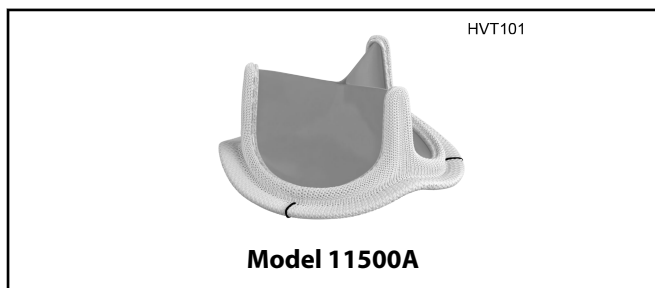

Edwards

## INSPIRIS RESILIA Aortic Valve, Model 11500A

### Instructions for Use



**CAUTION: Federal (USA) law restricts this device to sale by or on the order of a physician.**

### 1.0 Device and Accessories Description

#### 1.1 Device Description

The INSPIRIS RESILIA aortic valve, model 11500A, is a stented trileaflet valve comprised of RESILIA bovine pericardial tissue that is mounted on a flexible frame. The valve is stored under dry packaging conditions and consequently does not require rinsing prior to implantation. The valve is available in sizes 19, 21, 23, 25, 27, and 29 mm. See Table 1 for nominal dimensions.

**Table 1: Nominal Dimensions**

INSPIRIS RESILIA Aortic Valve, Model 11500A						
<b>Size (mm)</b>	19	21	23	25	27	29
1. Tissue Annulus Diameter (Stent Diameter, mm)	19	21	23	25	27	29
2. Internal Diameter (Stent ID, mm)	18	20	22	24	26	28

Edwards, Edwards Lifesciences, the stylized E logo, Carpentier-Edwards, COMMENCE, Edwards SAPIEN, Edwards SAPIEN XT, INSPIRIS, INSPIRIS RESILIA, Magna, Magna Ease, PERIMOUNT, RESILIA, SAPIEN, SAPIEN XT, and VFit are trademarks of Edwards Lifesciences Corporation. All other trademarks are the property of their respective owners.

3. Profile Height (mm)	13	14	15	16	17	18
4. External Sewing Ring Diameter (mm)	25	27	29	32	34	36
Geometric Orifice Area (mm <sup>2</sup> )	236	293	357	424	500	579
<b>Note: For Sizing, See Section 11.4 Device Implantation</b>						

#### 1.1.1 RESILIA Tissue

RESILIA tissue is created with a novel technology called Edwards Integrity Preservation. The technology incorporates a stable capping anticalcification process, which blocks residual aldehyde groups that are known to bind with calcium. The technology also incorporates tissue preservation with glycerol, which replaces the traditional storage in liquid-based solutions such as glutaraldehyde. The storage method eliminates tissue exposure to the residual unbound aldehyde groups commonly found in glutaraldehyde storage solutions.

#### 1.1.2 Valve Structure

The frame is designed to be compliant at the orifice as well as at the commissures. The compliance of the commissure supports is intended to reduce the loading shock at the valve commissures and free margin of the leaflets [Ref. 1]. The compliance of the orifice is intended to reduce the stress on the leaflets. The compliant orifice concept is based on the physiology and mechanics of natural heart valves and reported experience with implantation of unstented homografts [Refs. 2 & 3].

The lightweight wireform is made of a corrosion-resistant cobalt-chromium alloy, chosen because of its spring efficiency and fatigue-resistant characteristics, and is covered with a polyester fabric. A thin cobalt-chromium alloy band and polyester support band surround the base of the valve beneath the wireform frame providing structural support for the orifice.

In the INSPIRIS RESILIA aortic valve, the ends of the cobalt-chromium alloy band are secured by a polyester shrink-sleeve on the sizes 19 – 25 mm to allow the internal orifice of the valve to expand. The polyester support band allows expansion at each commissure when subjected to radial forces. The expandable cobalt-chromium alloy band does not impact suture placement or implant technique.

Valves with expandable bands (sizes 19 – 25 mm) (Figure 1) will maintain a stable diameter at implant and under intracardiac conditions which was demonstrated during compression resistance testing and accelerated wear testing during preclinical testing.

In the sizes 27 and 29 mm, the free ends of the cobalt-chromium alloy band are permanently secured using a weld joint (Figure 2).

A silicone-rubber sewing ring that is covered with a porous, seamless polytetrafluoroethylene (PTFE) cloth is attached to the wireform frame, and facilitates tissue ingrowth and encapsulation. The aortic sewing ring is scalloped to conform to the natural aortic root. The compliant nature of the sewing ring facilitates coaptation between the valve and an often irregular or calcific tissue bed.

To facilitate implantation in patients with small aortic roots, the model 11500A has a low profile height. The sewing ring has three equally spaced black silk suture markers at the cusp centers to aid in valve orientation and suture placement.

A holder is attached to the valve by means of sutures to facilitate handling and suturing the valve during implantation. The holder is detached by the surgeon. (See 11.4 Device Implantation).

Similar to other Edwards' bioprosthetic valves, the cobalt-chromium alloy wireform in the model 11500A can be identified on fluoroscopy. This allows for identification of the valve's inflow and outflow edges.

### 1.2 VFit Technology

VFit Technology is available on the model 11500A sizes 19 – 25 mm. This technology incorporates two novel features designed for potential future valve-in-valve (ViV) procedures: fluoroscopically visible size markers and an expandable cobalt chromium alloy band.

The fluoroscopically visible size marker is designed to aid the clinician in surgical valve size identification after implantation. A representation of the commissure size markers for the sizes 19 – 25 mm is shown in Figure 3.

**WARNING: SIZE MARKER CORRESPONDS TO THE LABELED VALVE SIZE OF THE INSPIRIS VALVE AND IS NOT A REPLACEMENT FOR CURRENT SIZE IDENTIFICATION TECHNIQUES RECOMMENDED FOR USE IN TRANSCATHETER PROCEDURES. Variability of patient anatomy and imaging quality may impact visibility of size markers and lead to misidentification of valve size.**

The band is expanded by the applied radial force of the transcatheter valve.

**WARNING: Valve-in-Valve procedures in an INSPIRIS valve should be performed according to the combinations in the SAPIEN XT valve IFU. Other combinations have not been evaluated and may result in the embolization of transcatheter devices anchored within or result in annular rupture.**

Reference Table 2 for specific internal diameter measurements of the INSPIRIS valve.

**Table 2: Dimensions of INSPIRIS RESILIA Aortic Valve — Internal Diameter Prior to ViV Expansion (mm)**

Labeled Valve Size	19	21	23	25
Measured Internal Diameter prior to Expansion <sup>1</sup>	18.8	20.7	22.5	24.6

<sup>1</sup> These data represent measurements by Edwards under fluoroscopy at the cobalt-chromium alloy band.

- Clinical data are not currently available on the model 11500A valve-in-valve procedure or expansion feature.
- The impact of tissue ingrowth on the expansion feature of the valve has not been assessed.
- Expansion has not been assessed with self-expanding transcatheter heart valves.

### IMPORTANT WARNINGS RELATED TO BAND EXPANSION:

**DO NOT PERFORM STAND-ALONE BALLOON AORTIC VALVULOPLASTY PROCEDURES ON THIS VALVE FOR THE SIZES 19 – 25 mm. Although the valve will maintain a stable diameter at implant and during intracardiac conditions, the diameter of this valve will expand if radial force is applied, such as during a balloon aortic valvuloplasty. This may expand the valve causing aortic incompetence, coronary embolism or annular rupture.**

### 1.3 Sizers and Tray

The use of a sizing instrument facilitates selection of the correct size valve for implantation. The translucent model 1133 sizers permit direct observation of their fit within the annulus. Each sizer consists of a handle with a different sizing configuration at each end (See Figure 4). On one side of the handle is a cylindrical end with an integrated lip that reflects the valve sewing ring geometry. On the other side of the handle is a valve replica end that reflects the valve sewing ring geometry as well as the height and location of the stent posts. A sizer is available for each size of the model 11500A valve (19, 21, 23, 25, 27, and 29 mm). The complete set of sizers is housed in a tray, model TRAY1133.

### 1.4 Valve Holder and Handle

The model 11500A valve has an integrated disposable holder. A malleable handle (model 1111 or model 1126) is attached to the holder at the time of surgery.

## 2.0 Intended Use and Indications for Use

The INSPIRIS RESILIA aortic valve, model 11500A, is intended for use as a heart valve replacement.

The INSPIRIS RESILIA aortic valve, model 11500A, is indicated for the replacement of native or prosthetic aortic heart valves.

## 3.0 Contraindications

There are no known contraindications with the use of the INSPIRIS RESILIA aortic valve.

## 4.0 Warnings

**FOR SINGLE USE ONLY.** This device is designed, intended, and distributed for single use only. Do not resterilize or reuse this device. There are no data to support the sterility, non-pyrogenicity, and functionality of the device after sterile reprocessing.

**DO NOT FREEZE OR EXPOSE THE VALVE TO EXTREME HEAT.** Exposure of the valve to extreme temperatures will render the device unfit for use. (Refer to Section 10.2 Storage, for recommended storage conditions).

**DO NOT USE the valve:**

- If the foil pouch, sealed trays or lids are opened, damaged, or stained
- If the expiration date has elapsed, or
- If it is dropped, damaged, or mishandled in any way. Should a valve be damaged during insertion, do not attempt repair.

**DO NOT EXPOSE the valve to any solutions, chemicals, antibiotics, etc., except for sterile physiological saline solution.** Irreparable damage to the leaflet tissue, which may not be apparent under visual inspection, may result.

**DO NOT GRASP the leaflet tissue of the valve with instruments or cause any damage to the valve.** Even the most minor leaflet tissue perforation may enlarge in time to produce significant impairment of valve function.

**DO NOT OVERSIZE.** Oversizing may cause valve damage or localized mechanical stresses, which may in turn injure the heart or result in leaflet tissue failure, stent distortion and regurgitation.

**DO NOT ADJUST THE VALVE DIAMETER BY EXPANDING THE BAND PRIOR TO/OR DURING IMPLANTATION OF THE SURGICAL VALVE.** The expandable band is not designed to allow for compression or expansion during implantation of the surgical valve. Doing so will cause damage to the valve and may result in aortic incompetence.

As with any implanted medical device, there is a potential for patient immunological response. Some components of the model 11500A are a metal alloy that contains cobalt, chromium, nickel, molybdenum, manganese, carbon, beryllium and iron. Care should be exercised in patients with hypersensitivities to these materials. This device was not made with natural rubber latex, but may have been produced in a latex-containing environment.

## 5.0 Adverse Events

### 5.1 Observed Adverse Events

As with all prosthetic heart valves, serious adverse events, sometimes leading to death, may be associated with the use of tissue valves. In addition, adverse events due to individual patient reaction to an implanted device or to physical or chemical changes to the components, particularly those of biological origin, may occur at varying intervals (hours or days) necessitating reoperation and replacement of the prosthetic device.

The INSPIRIS RESILIA aortic valve, model 11500A is similar in design to the Carpentier-Edwards PERIMOUNT Magna Ease pericardial aortic bioprosthesis, model 3300TFX.

Adverse events associated with the use of Carpentier-Edwards PERIMOUNT pericardial bioprostheses compiled from the literature and from reports received through the product surveillance system in accordance with the United States regulations establishing Good Manufacturing Practices, section 820.198, include stenosis, regurgitation through an incompetent valve, perivalvular leak, endocarditis, hemolysis, thromboembolism, thrombotic obstruction, bleeding diatheses related to the use of anticoagulation therapy, and malfunctions of the valve due to distortion at implant, fracture of the wireform, or physical or chemical deterioration of valve components. Types of tissue deterioration include infection, calcification, thickening, perforation, degeneration, suture abrasion, instrument trauma, and leaflet detachment from the valve stent posts. These complications may present clinically as abnormal heart murmur, shortness of breath, exercise intolerance, dyspnea, orthopnea, anemia, fever, arrhythmia, hemorrhage, transient ischemic attack, stroke, paralysis, low cardiac output, pulmonary edema, congestive heart failure, cardiac failure, and myocardial infarction.

### 5.2 Potential Adverse Events

Adverse events potentially associated with the use of valves and the surgical procedure include:

- Allergic reaction
- Angina
- Annulus (damage, dissection, tear)
- Arterial dissection
- Aorta (damage, dissection, tear)
- Aortic Root damage
- Asystole and/or cardiac arrest
- Bleeding
  - Peri- or post-procedural
  - Anticoagulant related
  - Pericardial tamponade
  - Hematoma
  - Cerebrovascular
- Blood - Anemia
- Blood - Coagulopathy
- Blood – Hemolysis/Hemolytic Anemia
- Blood Pressure alteration (hypotension, hypertension)
- Cardiac – Arrhythmias/Conduction Disturbances
- Cardiogenic shock
- Coronary artery ostia occlusion
- Deep vein thrombosis (DV)
- Disseminated intravascular coagulation (DIC)
- Embolism
- Endocarditis
- Esophageal tear/rupture
- Hypoxemia
- Infection – local, wound or systemic
- Multi-system organ failure (MOF)
- Myocardial infarction
- Neurologic Events

- Stroke (CVA)
- Transient Ischemic Attack (TIA)
- Pericardial effusion
- Pleural effusion
- Pneumonia
- Prosthetic Insufficiency –Regurgitation/Stenosis
- Pulmonary edema
- Reduced exercise tolerance
- Renal failure, acute
- Renal insufficiency
- Respiratory failure
- Thrombocytopenia, (Non-HIT)
- Thrombocytopenia, heparin induced (HIT)
- Thromboembolism
  - Arterial, venous, peripheral, central
- Transvalvular or Valvular Leaking
- Valve dislodgement/instability
- Valve – Nonstructural dysfunction
  - Paravalvular Leak
  - Leaflet impingement
  - Leaflet tissue damage (instruments/sutures)
  - Pannus
  - Prosthesis Mismatch (PPM) (due to inappropriate sizing)
  - Distortion at implant
- Valve - Structural dysfunction/deterioration
- Valve - Thrombosis
- Valve Wireform/Stent Fracture or Distortion

It is possible that these complications may lead to:

- Reoperation
- Explantation
- Permanent disability
- Death

## 6.0 Clinical Studies

The clinical safety and effectiveness of the INSPIRIS RESILIA aortic valve, model 11500A was established based on the outcome data of the COMMENCE trial, which assessed the Edwards Pericardial Aortic Bioprosthesis, model 11000A. The Edwards Pericardial Aortic Bioprosthesis, model 11000A, and the Edwards INSPIRIS RESILIA aortic valve, model 11500A, have a very similar design. The safety and effectiveness outcomes of the COMMENCE trial are applicable to model 11500A.

The COMMENCE trial is an open-label, prospective, non-randomized, multicenter trial without concurrent or matched controls. Following a pre-surgical assessment, subjects are followed for one year to assess primary safety and effectiveness. Subjects are followed annually thereafter for a minimum of five years post-surgical experience.

The trial population consists of adult subjects (18 years or older) diagnosed with aortic valve disease requiring a planned replacement of the native or prosthetic aortic valve. Concomitant coronary bypass surgery and ascending aorta resection and replacement from the

sinotubular junction without the need for circulatory arrest are permitted.

Trial candidates with prior valve surgery which included the implant of a prosthetic valve or annuloplasty ring that will remain *in situ* are excluded. Concomitant valve repair or replacement are excluded. Surgical procedures outside the cardiac area are not permitted. Various clinical presentations and histories may cause exclusion from the trial.

The reporting period for the COMMENCE trial aortic arm is January 2013 through February 2016. At the time of the database lock, six hundred ninety-four (694) subjects were enrolled at twenty-seven (27) investigational sites in the US and Europe. Of the enrolled population, six hundred eighty-nine (689) subjects were successfully implanted with the model 11000A and left the operating room with the trial valve.

Table 3 provides trial demographics, NYHA Classification and Risk Scores; Table 4 lists the observed adverse event rates during study; Table 5 gives the linearized late rates compared to the objective performance criteria (OPC); Table 6 lists the linearized late rates for valve-related events compared to the OPC; Table 7 provides NYHA Classification data at baseline and 1-year follow-up; and Table 8 lists hemodynamic parameters at 1-year.

In the clinical study, the analysis of effectiveness is based on NYHA functional classification and echocardiography data at one (1) year. Improvement in NYHA classification from baseline to the one year visit was observed based on subjects with available data at both time intervals. Based on Echocardiographic Core Lab assessments of echocardiography data, 97.9% of patients have no detectable or trivial aortic regurgitation at one year. Based on core lab assessments of echocardiography data, mean effective orifice areas (EOA) and mean gradients are consistent with current literature regarding other stented aortic bioprostheses and indicate acceptable hemodynamic performance of the Edwards Pericardial Aortic Bioprosthesis, model 11000A. The effectiveness outcomes of model 11000A are representative of model 11500A.

The results from the COMMENCE clinical trial demonstrate a 0.0% observed rate of structural valve deterioration (SVD) which is statistically less than 1% after 1-year of follow-up. Furthermore, the rates for all objective performance criteria (OPC)-defined adverse events are lower than the established standard of twice the FDA's Objective Performance Criteria for a bioprosthetic valve, with the exception of all bleeding and major bleeding. In the COMMENCE study the upper 95% confidence limit for the linearized rate for all bleeding was 3.7% and major bleeding was 2.2% which exceeds the FDA criterion of twice the OPC (all bleeding: 2.8% and major bleeding: 1.8%). However, detailed analysis of the major bleeding events showed no clear indication that the major bleeding were directly related to model 11000A valve. The CEC adjudicated valve-related events are provided in Table 6. The safety outcomes of model 11000A are representative of safety outcomes of model 11500A.

**Table 3: COMMENCE Trial Study Demographics**

<b>Age at Implant</b>	<b>N: Mean ± SD (Min - Max)</b>
Age (years)	689: 67.0 ± 11.6 (20 – 90)
<b>Sex</b>	<b>% (n / N)</b>
Female	28.2% (194 / 689)
Male	71.8% (495 / 689)
<b>NYHA Classification</b>	<b>% (n / N)</b>
Class I	24.1% (166 / 689)
Class II	49.6% (342 / 689)
Class III/IV	26.3% (181 / 689)
Class III	24.4% (168 / 689)
Class IV	1.9% (13 / 689)
<b>Risk Scores</b>	<b>N: Mean ± SD (Min - Max)</b>
STS risk of mortality (%) <sup>1</sup>	538: 2.0 ± 1.8 (0.3 – 17.5)
EuroSCORE II (%)	689: 2.5 ± 2.8 (0.5 – 24.6)

N is the number of subjects with available data for the given parameter.

<sup>1</sup> STS scores only calculated for subjects undergoing isolated AVR or AVR+CABG.

**Table 4: Observed Adverse Events**

<b>Adverse Event or Outcome</b>	<b>Early<sup>1</sup> (N = 689) n, m (%)</b>	<b>Late<sup>2</sup> (LPY<sup>3</sup> = 800.9) n, m (%/pt-yr)</b>	<b>Freedom- from Event at 1 Year (SE)<sup>4</sup></b>
All mortality	8, 8 (1.2)	18, 18 (2.2)	0.976 (0.006)
Valve-related mortality	3, 3 (0.4)	6, 6 (0.7)	0.988 (0.004)
Reoperation	1, 1 (0.1)	2, 2 (0.2)	0.997 (0.002)
Explant	0, 0 (0.0)	2, 2 (0.2)	0.998 (0.002)
Thromboembolism	15, 15 (2.2)	14, 17 (2.1)	0.965 (0.007)
Valve thrombosis	0, 0 (0.0)	0, 0 (0.0)	1.000 (0.000)
All bleeding	6, 6 (0.9)	21, 21 (2.6)	0.960 (0.008)
Major bleed	5, 5 (0.7)	11, 11 (1.4)	0.977 (0.006)
All Paravalvular Leak	2, 2 (0.3)	2, 2 (0.2)	0.994 (0.003)
Major PVL	1, 1 (0.1)	1, 1 (0.1)	0.997 (0.002)
Endocarditis	0, 0 (0.0)	5, 5 (0.6)	0.993 (0.004)
Hemolysis	0, 0 (0.0)	0, 0 (0.0)	1.000 (0.000)
Structural Valve Deterioration	0, 0 (0.0)	0, 0 (0.0)	1.000 (0.000)

<sup>1</sup> For 'Early Events' (events occurring thru post-implant day 30): For 'Early' m is the number of events; n is the number of subjects experiencing an event; % = n/N.

<sup>2</sup> For 'Late Events' (events occurring after post-implant day 30): m is the number of events; n is the number of subjects experiencing an event; and % = m/LPY.

<sup>3</sup> LPY: Late patient-years; LPY are calculated from post-implant day 31 until the last patient contact.

<sup>4</sup> Based on Kaplan-Meier analysis of time to first occurrence (early or late). Standard Error (SE) based on Greenwood's formula.

**Table 5: Linearized late rates compared to the OPC**

Adverse Event or Outcome	Late <sup>1</sup> (LPY <sup>2</sup> = 800.9) n, m (%/pt-yr)	95% UCL <sup>3</sup>	2X OPC <sup>4</sup>
Thromboembolism	14, 17 (2.1)	3.1	5.0
Valve thrombosis	0, 0 (0.0)	0.2	0.4
All bleeding	21, 21 (2.6)	3.7	2.8
Major bleeding	11, 11 (1.4)	2.2	1.8
All paravalvular leak	2, 2 (0.2)	0.7	2.4
Major paravalvular leak	1, 1 (0.1)	0.5	1.2
Endocarditis	5, 5 (0.6)	1.2	2.4

<sup>1</sup> For 'Late Events' (events occurring after post-implant day 30): m is the number of events; n is the number of subjects experiencing an event; and % = m/LPY.

<sup>2</sup> LPY: Late patient-years; LPY are calculated from post-implant day 31 until the last patient contact.

<sup>3</sup> UCL is the one-sided 95% Upper Confidence Limit for the linearized rate.

<sup>4</sup> FDA Objective Performance Criteria for tissue valves as described in Table R.1 of EN ISO 5840:2009, Annex R.1.

**Table 6: Linearized late rates for valve-related events compared to the OPC**

OPC Event	Late Events Late pt-yrs = 800.9 n, m (%/pt-yr)	Upper 95% CI	2X OPC
Thromboembolism	0, 0 (0.0)	0.2	5.0
Bleeding	0, 0 (0.0)	0.2	2.8
Major Bleeding	0, 0 (0.0)	0.2	1.8
Paravalvular Leak	2, 2 (0.2)	0.7	2.4
Major Paravalvular Leak	1, 1 (0.1)	0.5	1.2
Endocarditis	5, 5 (0.6)	1.2	2.4
Valve Thrombosis	0, 0 (0.0)	0.2	0.4
OPC Event	7, 7 (0.9)	1.6	—

'n' is the number of subjects with the event.

'm' is the number of events.

Major PV leaks are any PV Leak events resulting in surgical intervention or classified as an SAE.

Minor PV leaks are +3 or +4 on an echo core lab for a subject without a major PV leak. The first echo reading of +3/+4 is considered the onset of the minor PV Leak. A +2 PV leak on a core lab echo is also considered a minor leak if associated with a hemolysis AE.

**Table 7: NYHA Classification at Baseline and 1-Year**

NYHA Class	Baseline NYHA % (n / N <sup>2</sup> )	1-Year NYHA <sup>1</sup> % (n / N <sup>2</sup> )
Class I	24.0% (122 / 509)	80.7% (411 / 509)
Class II	49.7% (253 / 509)	17.3% (88 / 509)
Class III/IV	26.3% (134 / 509)	2.0% (10 / 509)
Class III	24.4% (124 / 509)	1.6% (8 / 509)
Class IV	2.0% (10 / 509)	0.4% (2 / 509)

<sup>1</sup> Improvement in NYHA observed demonstrated by a p-value < 0.0001 based on the test for marginal homogeneity after converting NYHA Class to numeric values (Class I = 1, Class II = 2, Class III = 3, Class IV = 4).

Values of 0 were replaced with 0.5 to avoid sparseness of data.

<sup>2</sup> N is the number of subjects who have both preoperative and 1 year NYHA data.

**Table 8: Hemodynamic Parameters at 1-Year**

Parameter	19 mm Mean ± SD (n <sup>1</sup> )	21 mm Mean ± SD (n <sup>1</sup> )	23 mm Mean ± SD (n <sup>1</sup> )	25 mm Mean ± SD (n <sup>1</sup> )	27 mm Mean ± SD (n <sup>1</sup> )
Mean Gradient (mmHg)	17.6 ± 7.8 (16)	12.6 ± 4.7 (97)	10.1 ± 3.8 (158)	9.6 ± 5.2 (132)	8.2 ± 3.5 (69)
EOA (cm <sup>2</sup> )	1.1 ± 0.2 (16)	1.3 ± 0.3 (97)	1.6 ± 0.4 (155)	1.8 ± 0.5 (131)	2.2 ± 0.6 (68)

<sup>1</sup> n represents the number of subjects with evaluable data for the specified valve size.

## 7.0 Post-Operation Management

Bioprosthetic heart valve recipients should be maintained on anticoagulation therapy, except where contraindicated, during the initial stages after implantation as determined by the physician on an individual basis. Long-term anticoagulation and/or antiplatelet therapy should be considered for patients with risk factors for thromboembolism.

## 8.0 Patient Selection

The ultimate judgment regarding care of a particular patient must be made by the healthcare provider and patient in light of all the circumstances presented by that patient [Ref. 4]. A bioprosthesis is recommended for AVR in patients of any age who will not take warfarin or who have major medical contraindications to warfarin therapy. Patient preference is a reasonable consideration in the selection of aortic valve operation and valve prosthesis. A mechanical prosthesis is reasonable for AVR in patients under 60 years of age who do not have a contraindication to anticoagulation. A bioprosthesis is reasonable for AVR in patients under 60 years of age who elect to receive this valve for lifestyle considerations after detailed discussions of the risks of anticoagulation versus the likelihood that a second AVR may be necessary [Ref. 4].

### 8.1 Specific Patient Populations

The safety and effectiveness of the model 11500A valve has not been established for the following specific populations because it has not been studied in these populations:

- Patients who are pregnant;
- Nursing mothers;
- Patients with abnormal calcium metabolism (e.g., chronic renal failure, hyperparathyroidism);
- Patients with aneurysmal aortic degenerative conditions (e.g., cystic medial necrosis, Marfan's syndrome);
- Children, adolescents, and young adults;
- Patients with hypersensitivity to metal alloys that contain cobalt, chromium, nickel, molybdenum, manganese, carbon, beryllium and iron;
- Patients with hypersensitivity to latex.

## 9.0 Patient Counseling Information

Careful and continued medical follow up (at least by an annual visit to the physician) is advised so that valve-related complications, particularly those related to

material failure, can be diagnosed and properly managed. Patients with valves are at risk from bacteremia (e.g., undergoing dental procedures) and should be advised about prophylactic antibiotic therapy. Patients should be encouraged to carry their Patient Identification Card at all times and to inform their healthcare providers that they have an implant when seeking care.

## 10.0 How Supplied

### 10.1 Packaging

The INSPIRIS RESILIA aortic valve, model 11500A, is provided sterile and nonpyrogenic, in a double barrier tray package. The double tray package is in a foil pouch, which is in a carton. Upon receipt of the carton, inspect the exterior for signs of damage.

Each valve is contained in a carton with a temperature indicator displayed through a window on the side panel. The temperature indicator is intended to identify products that were exposed to transient temperature extremes. Upon receipt of the valve, immediately inspect the indicator and refer to the carton label to confirm a "Use" condition. If the "Use" condition is not apparent, do not use the valve and contact the local supplier or Edwards Lifesciences representative to make arrangements for return authorization and replacement.

**WARNING: Carefully inspect the valve before implantation for evidence of extreme temperature exposure or other damage. Exposure of the valve to extreme temperatures will render the device unfit for use.**

### 10.2 Storage

The INSPIRIS RESILIA aortic valve, model 11500A, should be stored at 10 °C to 25 °C (50 °F to 77 °F), in the foil pouch and shelf carton.

## 11.0 Directions for Use

### 11.1 Physician Training

The techniques for implanting this valve are similar to those used for any stented aortic surgical valve. Only surgeons who have received appropriate training in surgical valve implantation should use the device.

### 11.2 Sizing

**WARNING: Fragments of handles and sizers are not radio-opaque and cannot be located by means of an external imaging device.**

**CAUTION: Do not use other manufacturer's valve sizers, or sizers for other Edwards Lifesciences valves,**

**to size the INSPIRIS RESILIA aortic valve, model 11500A.**

**CAUTION: Examine sizers for signs of wear, such as dullness, cracking or crazing, prior to use. Replace sizer if any deterioration is observed.**

Using the model 1133 sizer, select the cylindrical end of the largest diameter sizer that comfortably fits in the patient's annulus.

**11.2.1 Supra-annular sizing**

Step	Procedure
1	<p>For supra-annular implantation, the sewing ring of the valve is placed above the annulus, thereby maximizing the valve effective orifice area. When sizing for supra-annular implantation, the sizer should be parallel with the plane of the annulus and the following sizing technique should be used:</p> <ol style="list-style-type: none"> <li>Using the model 1133 sizer, select the cylindrical end of the largest diameter sizer that comfortably fits in the patient's annulus.</li> <li>Once the appropriate cylindrical end is verified, use the replica end of the same sizer to verify that the sewing ring will fit comfortably on top of the annulus. Ensure that the coronary ostia are not obstructed and that the stent posts of the replica end do not interfere with the aortic wall at the sinotubular junction. If satisfied with the fit of the replica end, choose this size of the valve for implant.</li> <li><b>Optional</b>-Determine if implanting a larger valve is possible by using the replica end of the next larger sizer. Ensure that the coronary ostia are not obstructed and that the stent posts of the replica end do not interfere with the aortic wall at the sinotubular junction. If the larger size replica end fits comfortably above the patient's annulus, implant this size of the valve. If the larger size replica end does not fit comfortably, implant the valve size identified in the previous step.</li> </ol>

**11.2.2 Intra-annular sizing**

Step	Procedure
1	<p>When an intra-annular technique is utilized, the entire valve including the sewing ring is placed inside the annulus. Either the cylindrical or replica end of the model 1133 sizer can be used for intra-annular sizing.</p> <p>For proper implantation of the valve in the intra-annular position, the sizer should be parallel with the plane of the annulus and the entire sizer, including the simulated sewing ring portion, should pass through the annulus.</p>
2	<p>Once the appropriate cylindrical end is verified, use the replica end of the same sizer to verify that the sewing ring will fit comfortably on top of the annulus. Ensure that the coronary ostia are not obstructed and that the stent posts of the replica end do not interfere with the aortic wall at the sinotubular junction. If satisfied with the fit of the replica end, choose this size of the valve for implant.</p>

**11.3 Handling and Preparation Instructions**

Step	Procedure
1	<p><b>WARNING: Check expiration date on packaging before use. Do not use product if expiration date has elapsed.</b></p> <p><b>WARNING: Do not open foil pouch into sterile field. Foil pouch is a protective cover only. The innermost package tray may be introduced into the sterile field.</b></p> <p><b>CAUTION: Do not open the INSPIRIS RESILIA aortic valve, model 11500A package until implantation is certain.</b></p>
2	<p>Once the appropriate size valve is chosen, remove the foil pouch from the carton in the non-sterile field. Before opening, examine the package for evidence of damage and broken or missing seals. Open pouch and remove tray in the non-sterile field (See Figure 5).</p>
3	<p>The valve inner tray is labeled with the work order number, model, size and serial number. The model, size and serial number should be confirmed with the number on the valve package and valve implant data card.</p> <p><b>CAUTION: If any difference in model, size or serial number is noted, the valve should be returned unused.</b></p>
4	<p>Near the sterile field, hold the base of the outer tray and peel the lid from the outer tray.</p>



Step	Procedure
5	The inner tray and contents are sterile. Transfer the inner tray to the sterile field. The contents of the inner tray must be handled using a sterile surgical technique to prevent contamination.
6	<p><b>CAUTION: Do not open the inner package until implantation is certain and the surgeon is ready to place the valve.</b></p> <p><b>CAUTION: The valve is not secured to the inner tray. Care should be taken while peeling the lid.</b></p> <p>Before opening, examine the inner tray and lid for evidence of damage, stains, and broken or missing seals. Hold the base of the inner tray and peel the lid from the inner tray.</p>
7	<p>Attach the handle, model 1111 or model 1126, to the valve holder while the valve is still in the tray. To attach, align the handle with the threaded hole in the valve's holder and turn clockwise until a positive resistance is felt. Aligning the handle will ensure a proper and secure attachment (See Figure 6, Figure 7).</p> <p><b>CAUTION: Do not grasp the valve with hands or surgical instruments.</b></p> <p><b>CAUTION: Examine the handle for signs of wear, such as dullness, cracking or crazing, prior to use. Replace handle if any deterioration is observed.</b></p> <p><b>CAUTION: Do not push the valve off the aortic retainer while attaching the handle to the holder.</b></p> <p><b>CAUTION: The handle/holder assembly is required for implantation and should not be removed until the valve is sutured to the annulus.</b></p>
8	Once the handle is attached, remove the valve and aortic retainer from the inner tray.

Step	Procedure
9	To remove the aortic retainer from the valve, firmly grasp the aortic retainer and pull away from the handle/holder assembly (See Figure 8 to Figure 11).
10	<p><b>The model 11500A, DOES NOT REQUIRE RINSING prior to implantation.</b></p> <p><b>CAUTION: If the valve is rinsed prior to implantation, it must then be kept hydrated with sterile physiological saline irrigation on both sides of the leaflet tissue throughout the remainder of the surgical procedure. Rinsing every one to two minutes is recommended.</b></p> <p><b>CAUTION: Avoid contact of the leaflet tissue with towels, linens, or other sources of particulate matter that may be transferred to the leaflet tissue.</b></p>

#### 11.4 Device Implantation

The INSPIRIS RESILIA aortic valve, model 11500A, is designed for supra-annular implantation and intra-annular implantation.

Step	Procedure	Step	Procedure
1	<p>The surgeon should be familiar with the recommendations for proper sizing and placement in the supra-annular and/or intra-annular position (See <b>11.2 Sizing</b>).</p> <p>Because of the complexity and variation of cardiac valve replacement surgery, the choice of surgical technique, appropriately modified in accordance with the previously described <b>Warnings</b>, is left to the discretion of the individual surgeon. In general, the following steps should be employed:</p> <ol style="list-style-type: none"> <li>Surgically remove the diseased or damaged valve leaflets and all associated structures deemed necessary.</li> <li>Surgically remove any calcium from the annulus to ensure proper seating of the sewing ring of the valve to avoid damage to the delicate leaflet tissue.</li> <li>Measure the annulus using only the aortic sizers, model 1133 (See Figure 4).</li> </ol> <p><b>CAUTION: When choosing a valve for a given patient, the size, age, and physical condition of the patient in relation to the size of the valve must be taken into consideration to minimize the possibility of obtaining a suboptimal hemodynamic result. The selection of a valve, however, must ultimately be made by the physician on an individual basis after carefully weighing all of the risks and benefits to the patient.</b></p>	3	<p>The spacing of the sutures in the remnant of the valvular orifice and the valve sewing ring must be carefully matched to avoid folding of the leaflets or distortion of the orifice. Edwards Lifesciences has received reports in which individual mattress sutures, spanning a distance of 10 to 15 mm, produced a purse string effect causing compression of the valve orifice.</p> <p>When using interrupted sutures, it is important to cut the sutures close to the knots and to ensure that exposed suture tails will not come into contact with the leaflet tissue.</p> <p><b>CAUTION: Avoid cutting or damaging the stent or delicate leaflet tissue when placing and cutting the sutures.</b></p> <p>Unlike rigid mechanical valves, the stent wall is soft and will not resist needle penetration. Accordingly, extreme care must be exercised when placing sutures through the sewing margin to avoid penetration of the side wall of the stent and possible laceration of the leaflet tissue.</p> <p>Once the sutures are completely tied, it is important to cut the sutures close to the knots to ensure that exposed suture tails will not come into contact with the leaflet tissue of the valve.</p> <p>As with all prostheses that have open cages, free struts, or commissure supports, care must be exercised to avoid looping or catching a suture around the commissure, which would interfere with proper valvular function.</p> <p>The stent of the aortic valve is symmetrical, and the commissure supports (struts) are equally spaced. The struts should correspond to the remnants of the natural commissures so as not to obstruct the coronary ostia.</p>
2	<p><b>Supra-annular placement</b></p> <p>A suture technique resulting in supra-annular placement of the valve, such as a non-everting horizontal mattress technique, should be employed.</p> <p><b>Intra-annular placement</b></p> <p>A suture technique resulting in intra-annular placement of the valve, such as an evverting mattress technique, should be employed.</p> <p>Due to the relative flexibility of the frame, care must be exercised to prevent folding or deformation of the stent that may lead to regurgitation, altered hemodynamics, and/or leaflet disruption rendering the valve incompetent. In this regard, oversizing must be avoided.</p>	4	<p>The integral holder and attached handle are removed as a unit at the completion of the suturing procedure (See Figure 12).</p> <ol style="list-style-type: none"> <li>Using a scalpel, cut each of the three exposed sutures that are on the top of the holder.</li> </ol> <p><b>CAUTION: Avoid cutting or damaging the stent or delicate leaflet tissue when cutting the holder sutures.</b></p> <ol style="list-style-type: none"> <li>After all three holder sutures are cut, remove the handle/holder assembly, along with the holder sutures, from the valve as a unit.</li> </ol>

Step	Procedure
	c) Remove the handle from the holder and discard the holder.

### 11.5 Accessory Cleaning and Sterilization

The accessories for the INSPIRIS RESILIA aortic valve, model 11500A, are packaged separately. The model 1126 handle is provided sterile and is intended for single use only. The model 1111 handle, the model 1133 sizers, and model TRAY1133 are reusable and are supplied nonsterile. Refer to the Instructions for Use supplied with the reusable accessories for cleaning and sterilization instructions.

### 11.6 Return of Valves

Edwards Lifesciences is interested in obtaining recovered clinical specimens of the INSPIRIS RESILIA aortic valve, model 11500A, for analysis. Contact the local representative for return of recovered valves.

- Unopened Package with Sterile Barrier Intact: If the foil pouch or trays have not been opened, return the valve in its original packaging.
- Package Opened but Valve is Not Implanted: If the tray is opened, the valve is no longer sterile. If the valve is not implanted, it should be placed into a suitable histological fixative such as 10% formalin or 2% glutaraldehyde and returned to the company. Refrigeration is not necessary under these circumstances.
- Explanted Valve: The explanted valve should be placed into a suitable histological fixative such as 10% formalin or 2% glutaraldehyde and returned to the company. Refrigeration is not necessary under these circumstances.

## 12.0 MRI Safety Information



### MR Conditional

Non-clinical testing has demonstrated that the INSPIRIS RESILIA aortic valve, model 11500A, is MR Conditional. A patient with the INSPIRIS RESILIA aortic valve, model 11500A, can be scanned safely under the following conditions:

- Static magnetic field of 1.5 tesla or 3 tesla only.
- Maximum spatial gradient magnetic field of 3,000 gauss/cm (30 T/m) or less.
- Maximum MR system-reported, whole-body averaged specific absorption rate (SAR) of 2.0 W/kg in Normal Operating Mode.

Under the scan conditions defined above, the INSPIRIS RESILIA aortic valve, model 11500A, is expected to produce a maximum *in vivo* temperature rise of less than 2.0 °C at 1.5 T and less than 2.5 °C at 3 T after 15 minutes of continuous scanning.

In non-clinical testing, the image artifact extends approximately 10 mm from the model 11500A valve when imaged with a spin echo pulse sequence and 17 mm from the device when imaged with a gradient echo pulse sequence and a 3 tesla MRI system. The artifact obscures the device lumen.

## 13.0 Patient Labeling

### 13.1 Patient Identification Card

A Patient Identification Card is provided to each patient implanted with the INSPIRIS RESILIA aortic valve, model 11500A.

### 13.2 Patient Information

Patient information materials may be obtained from Edwards or an Edwards clinical sales specialist.

## 14.0 References





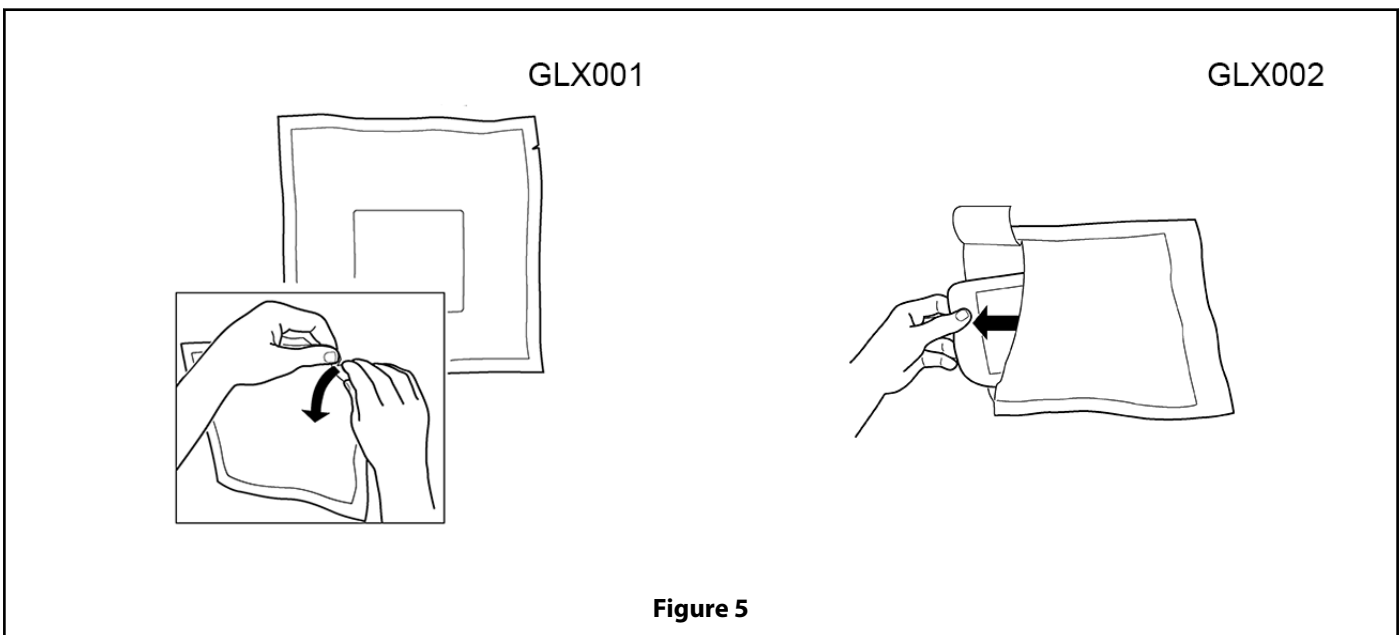
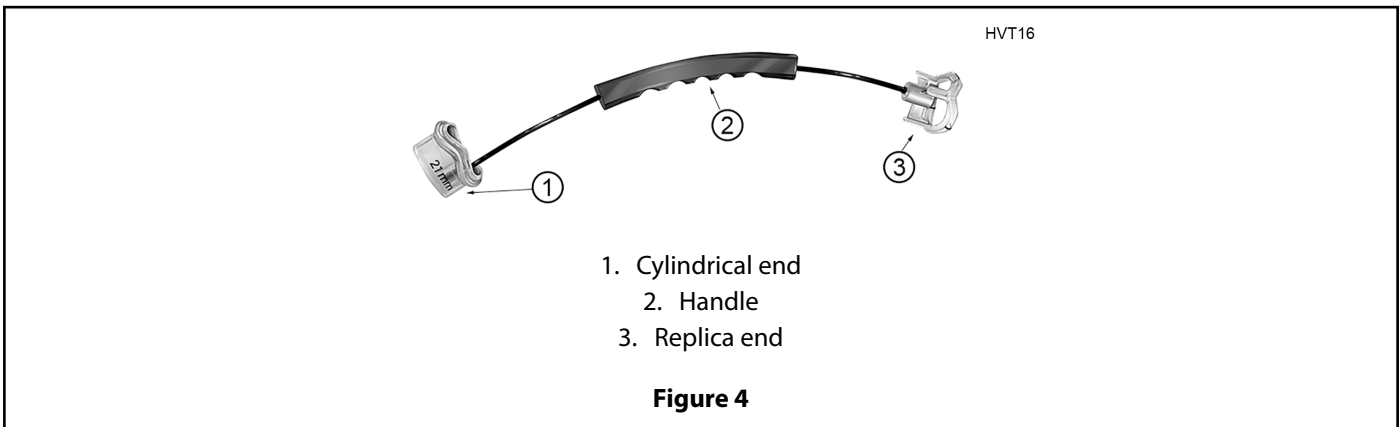
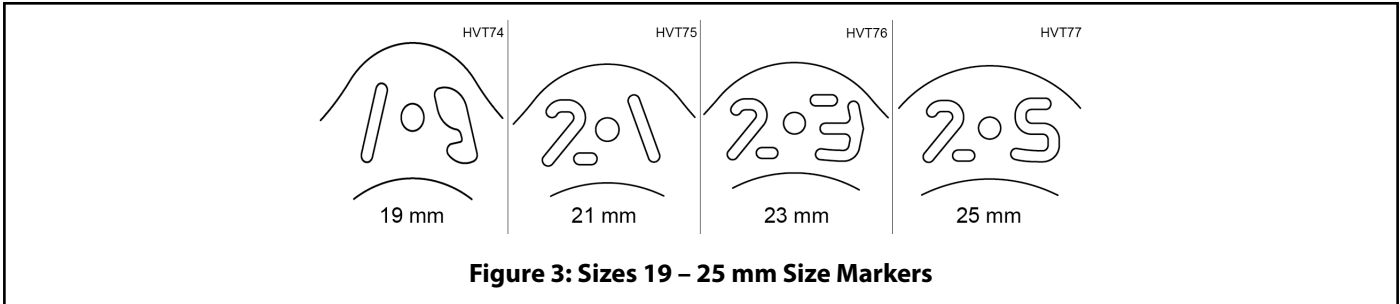
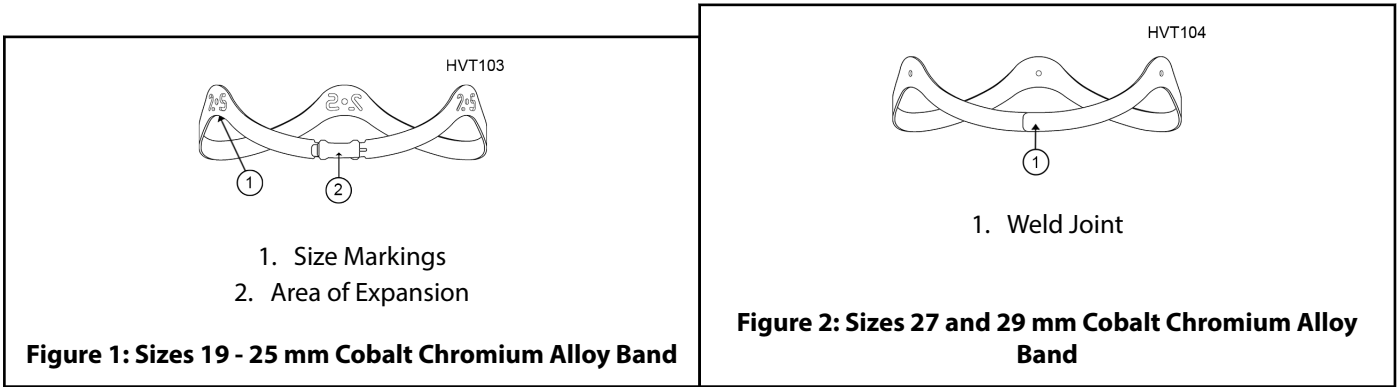

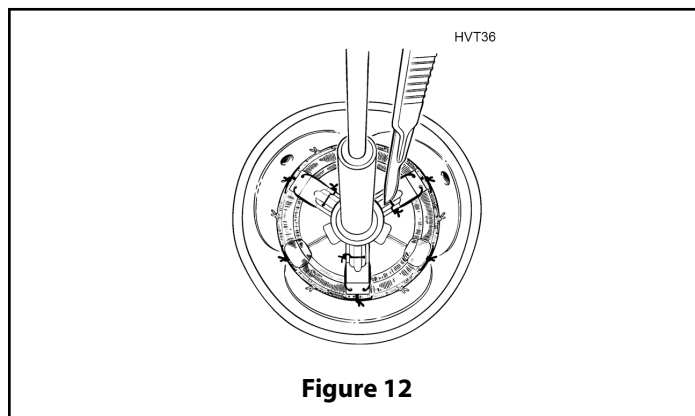
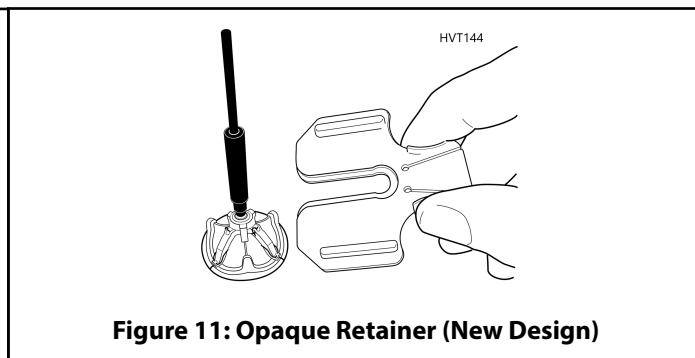
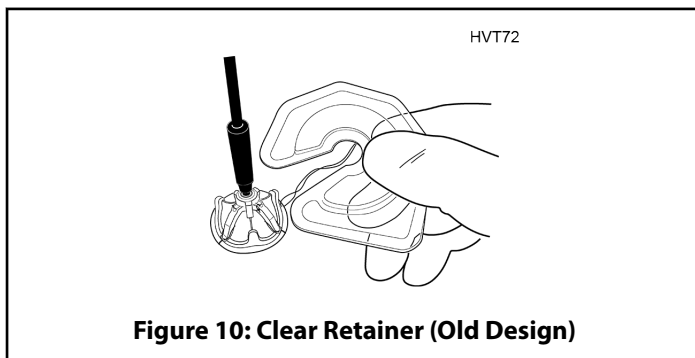
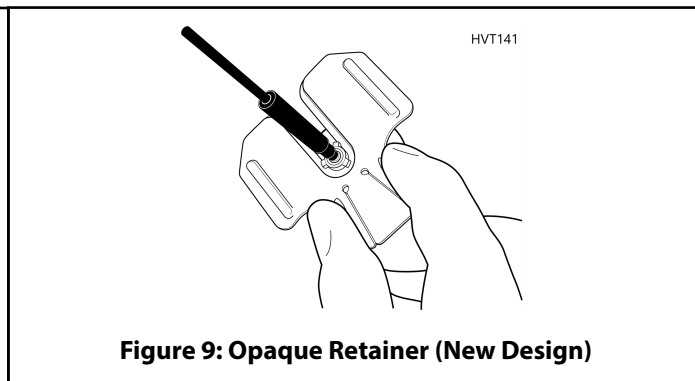
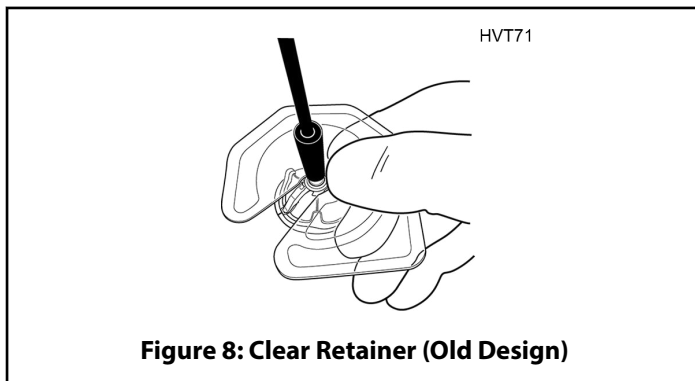
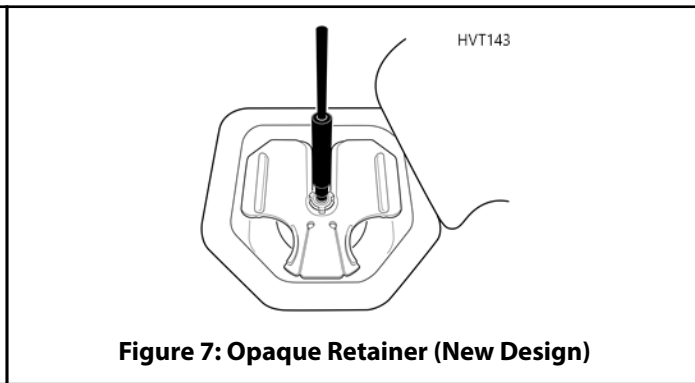
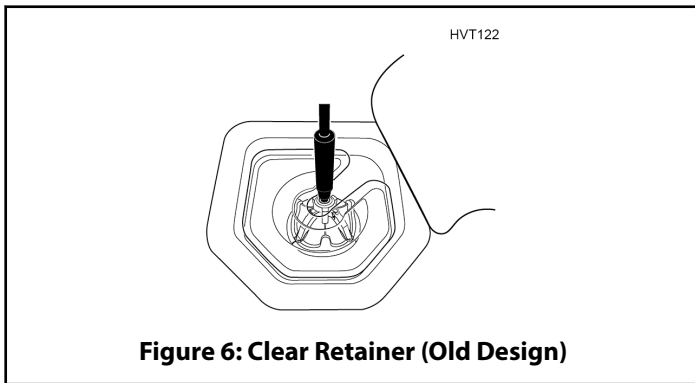

1. Reis, Robert L., et al. The Flexible Stent. A new concept in the fabrication of tissue heart valve prostheses. *J. Thorac Cardiovasc Surg* 1971, 62(5):683:689.
2. Barrat-Boyes, B.G. and A.H.G. Roche. A review of aortic valve homografts over a six and one-half year period. *Ann Surg* 1969, 170:483-492.
3. Brewer, R.J., et al. The dynamic aortic root. Its role in aortic valve function. *J Thorac Cardiovasc Surg* 1976, 72:413-417. Reis, Robert L., et al. The Flexible Stent. A New Concept in the Fabrication of Tissue Heart Valve Prostheses. *J Thorac Cardiovasc Surg* 1971, 62(5):683-689 and 693-695.
4. Bonow R.O., et al. ACC/AHA Guidelines for the Management of Patients with Valvular Heart Disease: A Report of the American College of Cardiology/ American Heart Association Task Force on Practice Guidelines (Committee on Management of Patients With Valvular Heart Disease). *J Am Coll Cardiol* 2014, 63:e57-185.



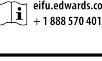

## Figures





## Symbol Legend

	ISO Reg. No. <sup>1</sup>	English
	N/A	Catalogue Number
	2498	Serial Number
	N/A	Size
	N/A	Quantity
	1641	Consult instructions for use
	1641	Consult instructions for use on the website
	2607	Use-by date
	0434A	Caution
	N/A	MRI Safety Information. See requirements.
	1051	Do not re-use

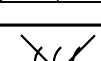
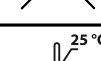
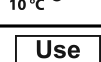
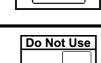
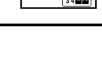
	ISO Reg. No. <sup>1</sup>	English
	2606	Do not use if package is damaged
	N/A	Conformité Européenne (CE Mark)
	2497	Date of manufacture
	3082	Manufacturer
	2501	Sterilized using ethylene oxide
	N/A	Authorized representative in the European Community
	2724	Non-pyrogenic
	0632	Temperature Limit
	N/A	Use product if indication is shown
	N/A	Do not use product if indication is shown

**Note:** The labeling of this product may not contain every symbol depicted in the legend.

<sup>1</sup> ISO 7000 *Graphical symbols for use on medical equipment - Registered symbols*



10/22  
10046478002 A  
© Copyright 2022, Edwards Lifesciences LLC  
All rights reserved.